



NSF International

EXECUTIVE SUMMARY

The Multi-Flo Waste Treatment Systems, Inc. Model FTB-0.5 was tested under the provisions of ANSI/NSF Standard 40 for Individual Aerobic Wastewater Treatment Plants (1990), which was developed by the NSF Joint Committee on Wastewater Technology. The performance evaluation was conducted at the NSF Wastewater Technology Test Facility in Chelsea, Michigan, using wastewater diverted from the Chelsea municipal wastewater collection system. The evaluation consisted of six months of testing, during which a seven week stress test was conducted. The evaluation consisted of three weeks of dosing without sampling to allow for plant start-up, sixteen weeks of dosing at design flow, seven weeks of stress test and five weeks of dosing at design flow. Sampling started in the fall and continued through the winter and into spring, covering a full range of operating temperatures.

Section H. (3), in Appendix A of Standard 40, provides for exclusion of up to ten percent of effluent sample days, not to exceed one during stress testing, in completing the pass/fail determination. Other than samples collected for information only, no sample days were excluded in the pass/fail determination for this evaluation. The average effluent BOD₅ was 5 mg/L during the evaluation, ranging between <5 and 12 mg/L, and the average effluent suspended solids was 5 mg/L, ranging between <5 and 8 mg/L. The Model FTB-0.5 produced an effluent that successfully met the performance requirements established by NSF Standard 40 for Class I effluent:

The maximum arithmetic mean of seven consecutive sample days was 5 mg/L for BOD₅ and 5 mg/L for suspended solids, both well below the allowed maximum of 45 mg/L. The maximum arithmetic mean of 30 consecutive sample days was 5 mg/L for BOD₅ and 5 mg/L for suspended solids, both well below the allowed maximum of 30 mg/L. Removal rates ranged from 96 to 97 percent for BOD₅ and 97 to 98 percent for suspended solids, consistently above the requirement of 85 percent. The effluent pH during the entire evaluation ranged between 7.3 and 8.1, within the required range of 6.0 to 9.0. The plant also met the requirements for noise levels (less than 80 dbA at a distance of 20 feet) and color, threshold odor, oily film and foam.

SUMMARY OF ANALYTICAL RESULTS

	<u>Average</u>	<u>Std.Dev.</u>	<u>Minimum</u>	<u>Maximum</u>	<u>Median</u>	<u>Interquartile Range</u>
BOD ₅ (mg/L)						
<i>Influent</i>	150	31	66	220	170	130-170
<i>Effluent</i>	5	0.1	<5	12	5	<5-5
Suspended Solids (mg/L)						
<i>Influent</i>	195	66	52	480	180	150-230
<i>Aeration Chamber</i>	4,220	2,780	7	10,000	4,200	1,600-6,700
<i>Effluent</i>	5	0.3	<5	8	5	<5-5
Volatile Suspended Solids (mg/L)						
<i>Influent</i>	158	47	48	390	150	130-180
<i>Aeration Chamber</i>	3,000	1,920	6	7,500	3,100	1,200-4,700
<i>Effluent</i>	5	0.3	<5	8	5	<5-5
pH						
<i>Influent</i>	-	-	7.2	7.8	7.5	7.5-7.5
<i>Aeration Chamber</i>	-	-	7.1	7.9	7.4	7.4-7.5
<i>Effluent</i>	-	-	7.3	8.1	7.7	7.6-7.8
Dissolved Oxygen (mg/L)						
<i>Aeration Chamber</i>	6.8	1.2	2.3	9.1	7.0	6.4-7.6
<i>Effluent</i>	2.5	0.6	0.8	5.9	2.5	2.3-2.7

MULTI-FLO WASTEWATER TREATMENT PLANT

PROCESS TREATMENT

The MULTI-FLO wastewater treatment plant combines the processes of aerobic biological treatment and mechanical filtration.

By definition, the system is a complete mix extended aeration modification of the activated sludge process.

To further clarify the process functions of the MULTI-FLO, let us consider what complete mix and extended aeration treatment consists of and what advantages they provide to the MULTI-FLO design.

Complete Mix Activated sludge plants that use aeration tanks in which the influent wastewater is thoroughly mixed throughout the tank. In a completely mixed system, the concentration of solids, dissolved oxygen and substrate (BOD) remaining are the same at every point in the tank.

The basic advantage of the complete mix system is that any shocking load or toxic waste is immediately diluted by the entire contents of the aeration tank.

Extended Aeration Due to the long aeration detention time, usually twenty-four hours or more, this process offers a high degree of BOD removal with 95% to 98% being common. The system requires that microorganisms exist in the endogenous phase of respiration by maintaining a low food-to-microorganism ratio in the system. This ratio is produced by maintaining a low BOD loading, a high mixed liquor suspended solids (MULTI-FLO typically operates in a range of 5,000 to 6,000mg/l of total suspended solids), and a long retention time. The extended aeration process is quite stable under variable flow and loading conditions. It is sometimes referred to as the "total oxidation process".

By combining the complete mix and extended aeration process, the MULTI-FLO plant is enabled to withstand variable loading conditions. The ability of the MULTI-FLO to react to shock loads demonstrates the ability to handle a BOD application rate almost three times that of a conventional extended aeration system. With these capabilities the MULTI-FLO wastewater plant is ideally suited to on-site applications.

To compare the MULTI-FLO process design with the other extended aeration package plants, you must involve multi-compartments to accomplish secondary treatment and filtration, whereas the MULTI-FLO system accomplishes the same functions of these systems within one tank.

Note that it takes separate aeration compartments, a secondary clarifier compartment, return sludge airlift, and a digester compartment to accomplish secondary treatment.

Filtration would require an additional structure. The MULTI-FLO wastewater plant completes the same functions within one compartment including aerobic digestion and in addition filters the effluent. At this point in the discussion let us consider the mechanics of the MULTI-FLO plant and how it physically accomplishes its process.

The MULTI-FLO aerator is a 1/6 hp venture pump which delivers 2880 cubic feet of air per day. Oxygen is transferred to the aeration tank at a rate of 3.6 lbs. per day which is sufficient to remove 1.5 lbs. of BOD per day.

The flow of air produced in the mixing chamber induces a pattern of circulation in the process fluid. In the chamber, fluid travels upward and a portion is diverted out and away from the center just below the filter support plate. Hence, fluid circulates horizontally across the hanging filter tubes. Along the outside walls of the aeration chamber, fluid travels downward and then along the bottom of the chamber back to the aerator.

The MULTI-FLO filters are suspended vertically in the process fluid and are cylindrical, closed at the bottom; they are made of a polyester felted material. Each filter contains a polyethylene expander. This resists hydraulic pressure from the process fluid which would cause the filter to collapse. As the process matures, the surface of each filter accumulates a mass of aerobic bacteria. The extent of bacterial buildup is limited and regulated by the constant washing action of the horizontal flow of the process fluid. In addition, a natural sluffing of inert solids takes place which also limits the buildup of activated sludge. This is similar to what takes place in the trickling filter process of sewage treatment.

The MULTI-FLO filtering system utilizes 135 square feet of filter area. Based on a 500 gallon per day flow, this is equivalent to a 3.7 gallon per square feet per day filter loading rate.

The MULTI-FLO process design allows for solids separation to occur at the point where the mixed liquor suspended solids (MLSS) are passed horizontally across the filter tubes. The clear effluent penetrates the filters and rises upwards, while the solids are retained in the mixing chamber. The action of solids settling involves heavy inert materials settling within a quiescent area of the mixing chamber located from the impeller of the pump upwards to the filters.

A major aspect of this design is that during low or no loading periods of operation, the system functions as an aerobic digester, reducing the solids build-up in the system.

Due to the high level of oxygen transferred to the process, a dissolved oxygen content of 5.0 mg/l to point of saturation, an amount of activated sludge is digested or oxidized to an ash state wasting for a period of two to three years on an average. The sludge age in a typical package plant would be between fifteen to thirty days.

The filter operation of this design does not dictate a backwash system due to the washing action of the pump and natural sluffing effect. However, filter cleaning is required normally every two to three years.

To summarize our discussion of the process of the MULTI-FLO wastewater treatment plant, let us evaluate the final product results. BOD and TSS removal efficiency is 96% to 98%, pathogenic bacteria removal efficiency is greater than 99%, virus removal efficiency is 99% to 100%, resulting in clear odorless effluent suitable for surface and subsurface discharge.

Additional advantages include a system that is not operator sensitive, i.e.; daily sludge wasting is not needed. There are no return sludge adjustments needed to be made. There is no filter backwashing required. Very little maintenance is needed due to the fact you only have one mechanical part (aerator). An alarm system is provided decreasing need for visual inspections. Filter maintenance is done only periodically and is simply accomplished. The process design also protects against solids carry-over associated with bulking sludge conditions. You cannot by-pass raw untreated sewage through the system.

The MULTI-FLO plant can be summarized as a highly efficient, sophisticated wastewater treatment system which utilizes a very simple mechanical design.

SEWAGE TREATMENT SYSTEM

SPECIFICATIONS FOR:

GENERAL

There shall be furnished _____ complete MULTI-FLO Sewage Treatment System(s), Model _____, to be used for the treatment of the sewage from _____.

Each system shall consist of an aeration tank, _____ aerator(s), _____ filters, and an alarm control system. All necessary piping to connect the unit (s) to the sources of inlet and outlet will be supplied by the contractor.

OPERATING CONDITIONS

The plant shall be capable of treating _____ gallons per day of sanitary sewage or waste with a 5-day BOD not to exceed 240 ppm.

MULTI-FLO AERATOR MODEL A-10031

Each MULTI-FLO Sewage Treatment System, Model _____, will be furnished with _____ aerator (s) Model A10031. The aerator is an oil-filled submersible mechanical aerator placed at the bottom of the aeration tank. The aerator draws air into the plant through a vertical pipe due to the suction created by a rotating impeller. The air is dispersed radially near the bottom of the chamber.

AERATOR SPECIFICATIONS:

- Open Impeller – plastic
- Motor Housing – coated cast iron
- Fastener Items – stainless steel
- 1/6 H.P., P.S.C. Motor
- 115 Volt AC, 60 HZ, 1.8 amps
- 1550 RPM Motor built-on thermal overload protection of 135⁰
- Oxygen transfer rate of 3.6 lbs./ day
- Will aerate and metabolize 1.5 lbs. of BOD₅
- Air delivery – 100 to 200 CFH

MULTI-FLO AERATION TANK

The aeration tank shall be constructed of fiberglass reinforced polyester formulated to resist the acid contained in the soil. The inside surface of the tank basin will be gel-coated. The thickness of all parts will be 3/16" + 1/16" –0. An inlet and outlet pipe of 4-inch PVC pipe, Schedule 40 being 4 inches long will be supplied as an integral part of the tank.

MULTI-FLO FILTRATION SYSTEM

Each MULTI-FLO Sewage Treatment System, Model _____, will be furnished with _____ filters, totaling _____ square feet of filtration area. Each filter is produced of a felted polyester scrim reinforced material that is chemically and biologically inert. Each filter will contain a polyethylene “expander” that resists hydraulic pressure from the process fluid and keeps the filter extended in the full operating position.

MATERIAL SPECIFICATIONS:

- Fiber type – polyester
- Scrim Reinforced
- Air Permeability – 415 to 690
- Burst Strength (PSI) – 350
- Expander – 3” slotted and drilled polyethylene pipe

MULTI-FLO AUTOMATIC ALARM SYSTEM

An automatic alarm system shall be furnished with each MULTI-FLO Sewage Treatment unit. The alarm will provide an audible/visual indication of the loss of air supply of the evidence of high water in the system.

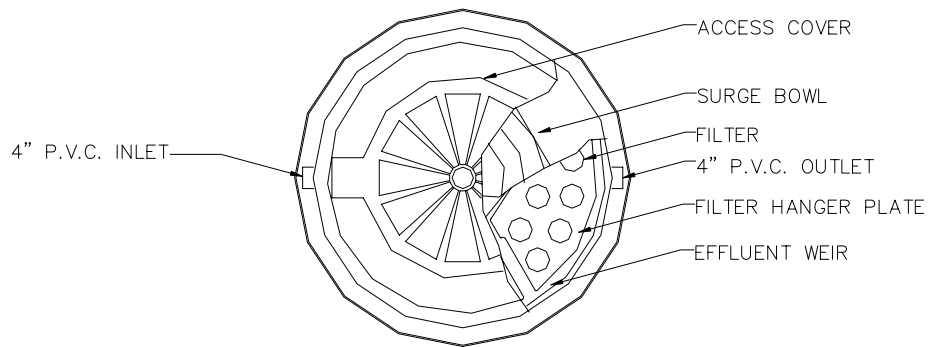

PLAN VIEW

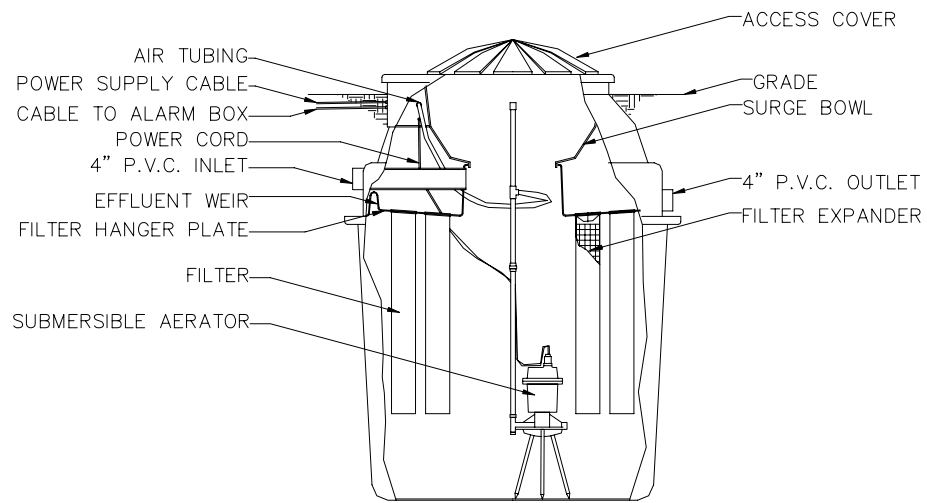

ELEVATION SECTION

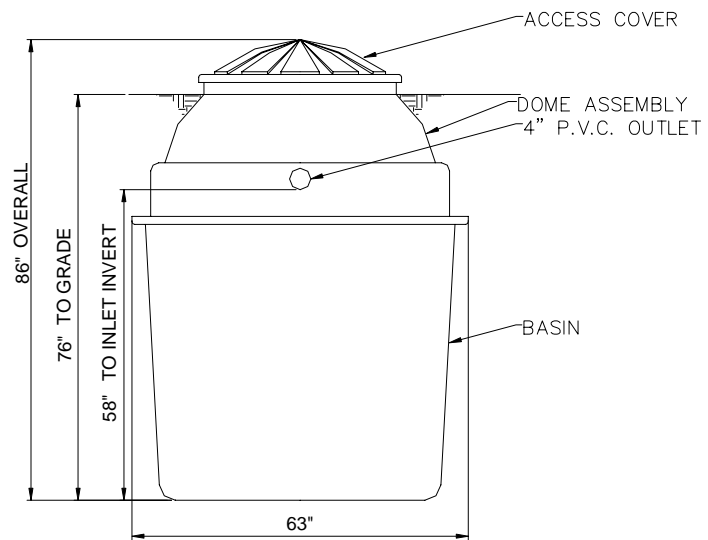

OUTLET END ELEVATION

MULTI-FLO FTB-0.5

Date:
09/05/2002
Drawn By:
BDB
Scale:
AS SHOWN

Consolidated Treatment Systems, Inc.
1501 Commerce Center Drive, Franklin, OH 45005-1891
1-937-746-2727 www.multi-flo.com
Bennette D. Burks, P.E.

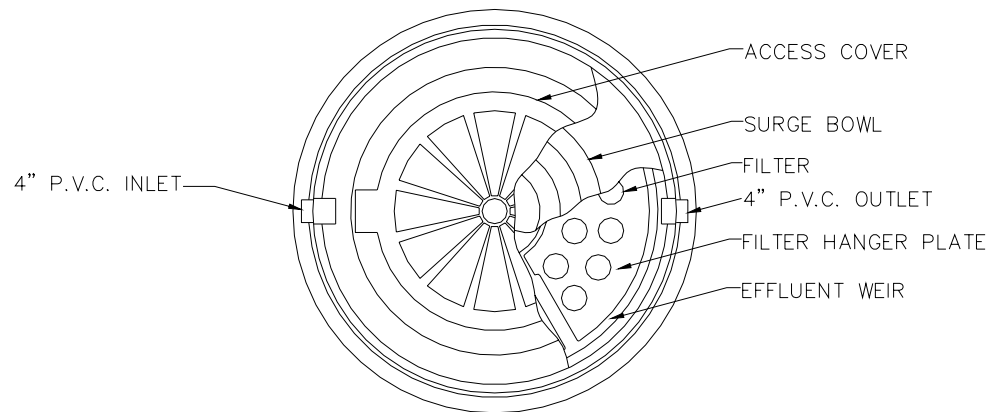

PLAN VIEW

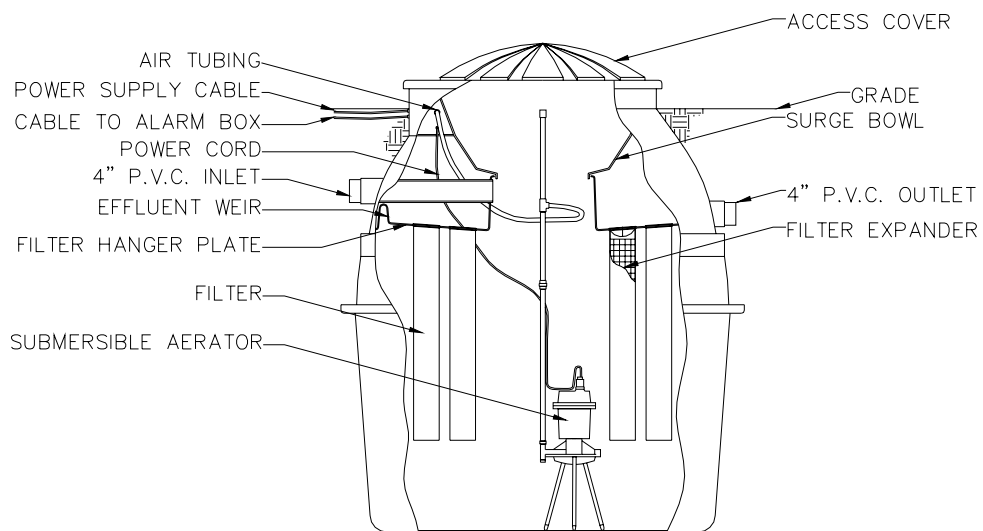

ELEVATION SECTION

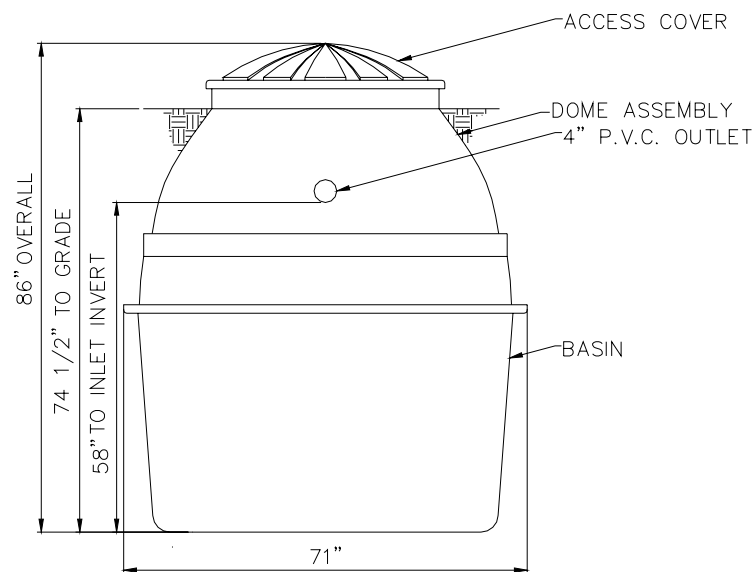

OUTLET END ELEVATION

MULTI-FLO FTB 0.6

Date:
09/05/2002
Drawn By:
BDB
Scale:
AS SHOWN

Consolidated Treatment Systems, Inc.
1501 Commerce Center Drive, Franklin, OH 45005-1891
1-937-746-2727 www.multi-flo.com
Bennette D. Burks, P.E.

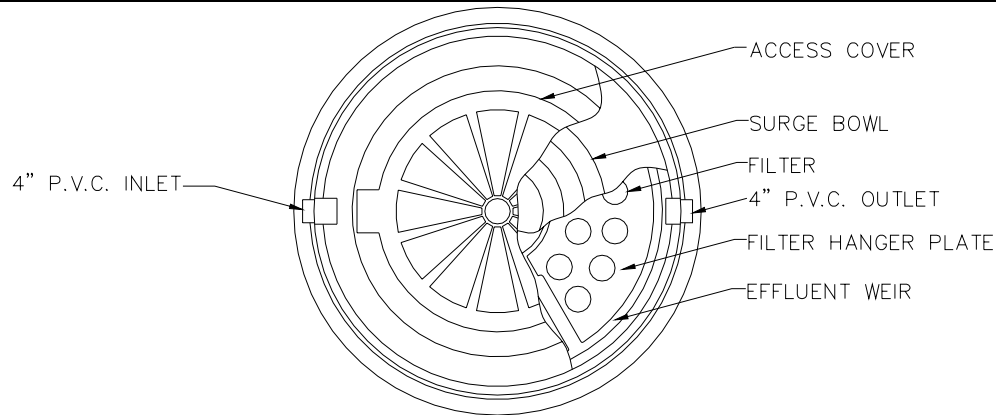

PLAN VIEW

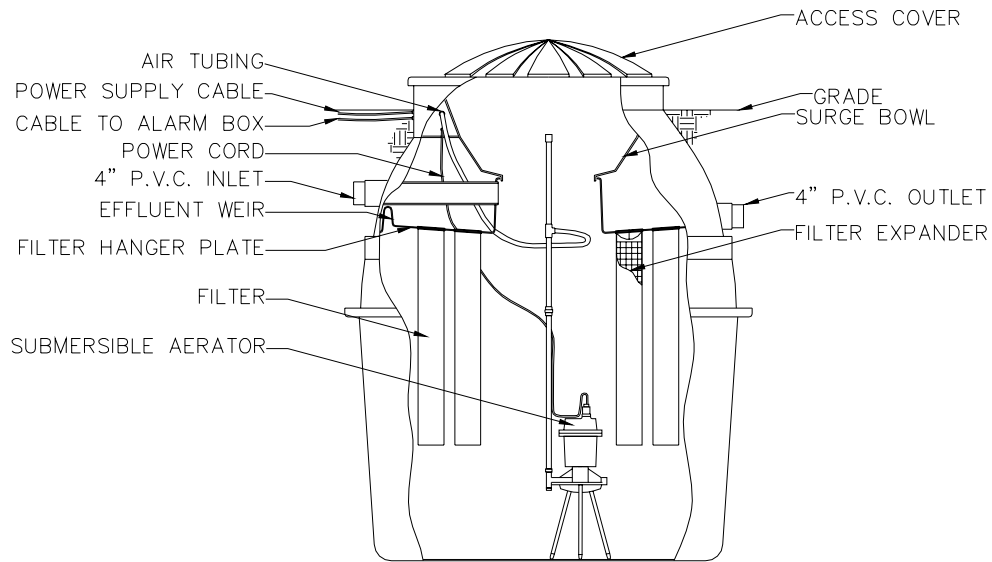

ELEVATION SECTION

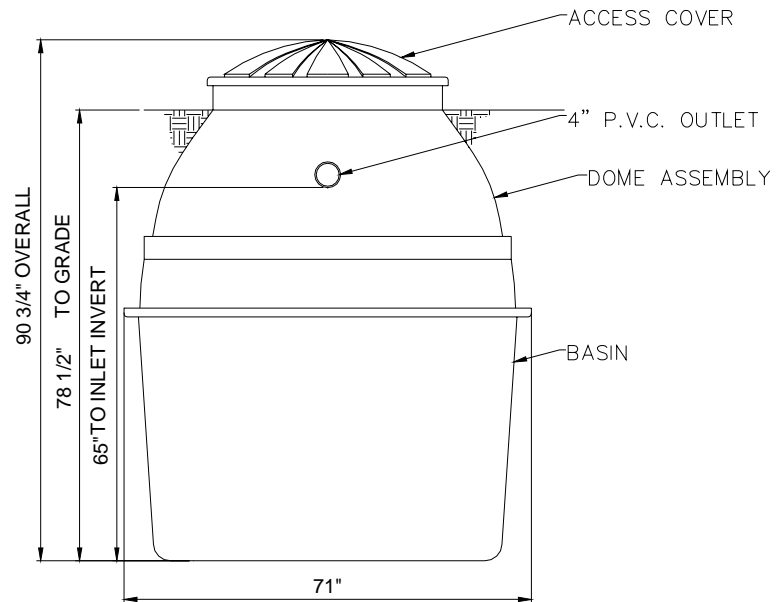

OUTLET END ELEVATION

MULTI-FLO FTB 0.75

Date:
09/05/2002
Drawn By:
BDB
Scale:
AS SHOWN

Consolidated Treatment Systems, Inc.
1501 Commerce Center Drive, Franklin, OH 45005-1891
1-937-746-2727 www.multi-flo.com
Bennette D. Burks, P.E.

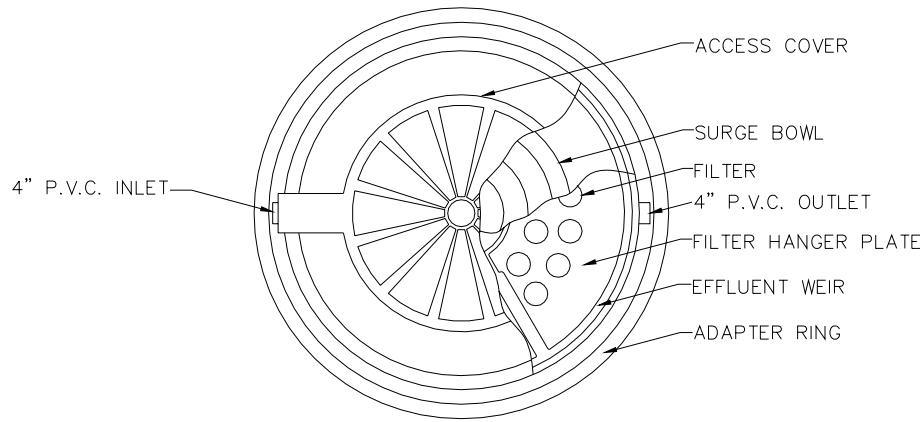

PLAN VIEW

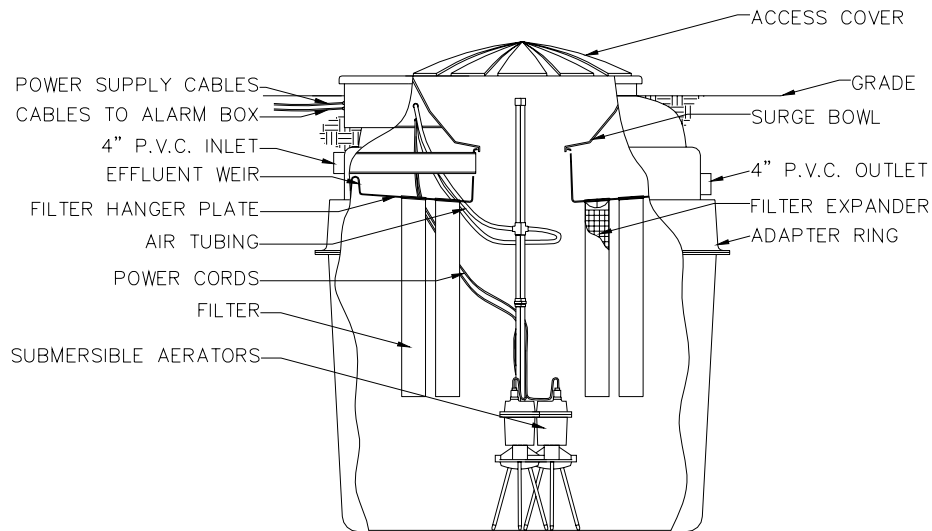

ELEVATION SECTION

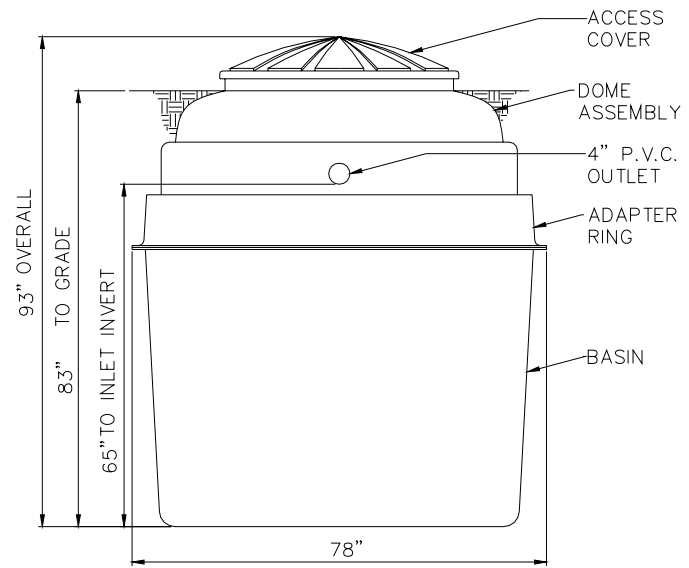

OUTLET END ELEVATION

MULTI-FLO FTB 1.0

Date:
09/05/2002
Drawn By:
BDB
Scale:
AS SHOWN

Consolidated Treatment Systems, Inc.
1501 Commerce Center Drive, Franklin, OH 45005-1891
1-937-746-2727 www.multi-flo.com
Bennette D. Burks, P.E.

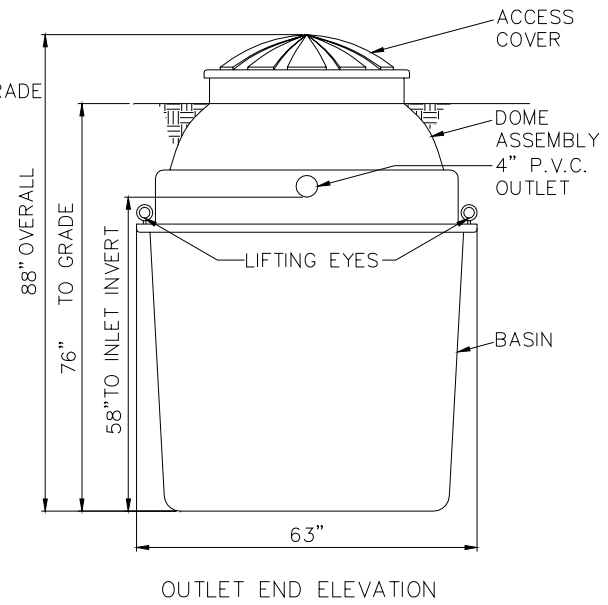
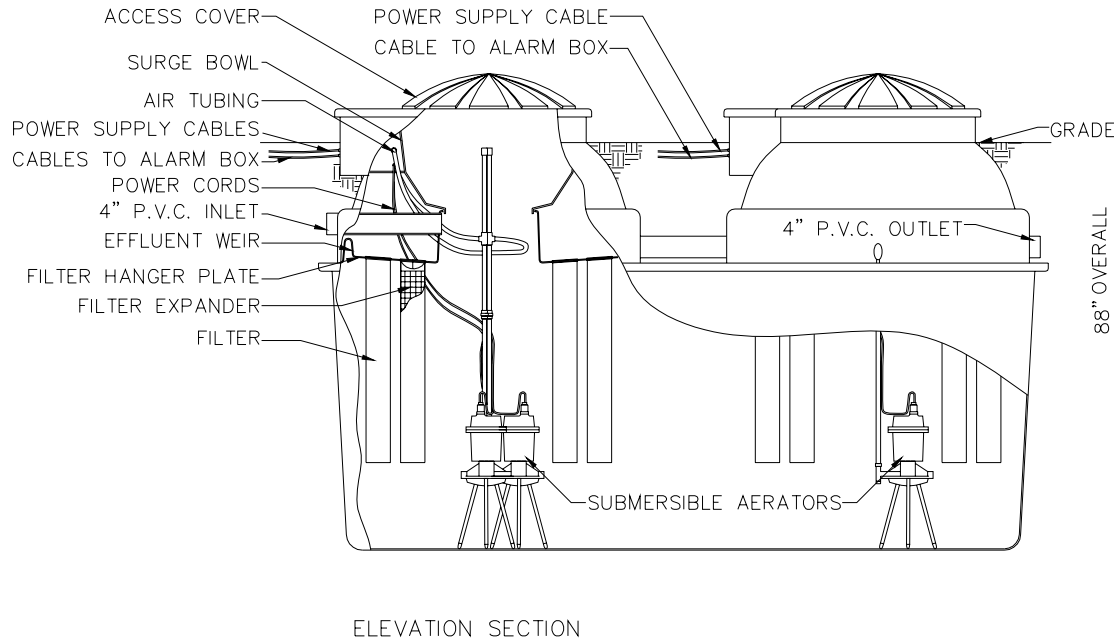
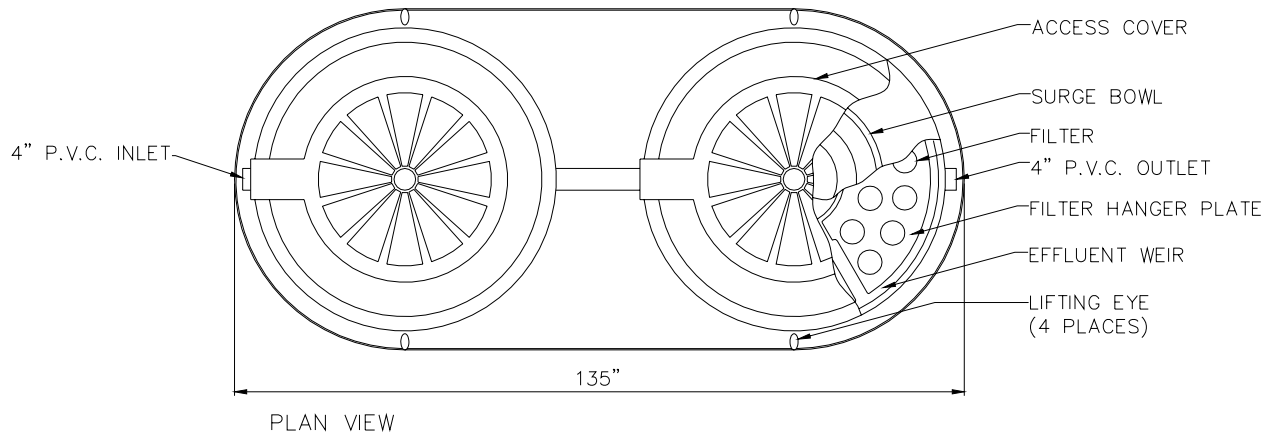

MULTI-FLO FTB 1.5

Date:
09/05/2002
Drawn By:
BDB
Scale:
AS SHOWN

Consolidated Treatment Systems, Inc.
1501 Commerce Center Drive, Franklin, OH 45005-1891
1-937-746-2727 www.multi-flo.com
Bennette D. Burks, P.E.

MULTI-FLO

MULTI-FLO WASTEWATER TREATMENT SYSTEMS

OWNER'S MANUAL

**Consolidated Treatment Systems, Inc.
1501 Commerce Center Drive
Franklin, OH 45005
937-746-2727
www.multi-flo.com**

Revised October 2002

THE MULTI-FLO ONSITE WASTEWATER TREATMENT SYSTEM

CONGRATULATIONS! You are the owner of a complete wastewater treatment system that combines aeration and filtration in one compact unit. Your system is tested and certified under NSF International, ANSI/NSF Standard 40, as a Class I system. The MULTI-FLO system meets the needs for onsite wastewater treatment beyond the capabilities of septic tanks. Like all onsite wastewater treatment alternatives, your MULTI-FLO unit must be operated and maintained in accordance with the Manufacturer's requirements and service provider's instructions. When properly operated and maintained, your unit will produce an effluent that meets all certification requirements.

HOW DOES THE MULTI-FLO OPERATE?

One of the features of the MULTI-FLO is that the entire treatment process takes place within a single tank. Wastewater flows into the tank. An aerator near the bottom draws air in and disperses it. This process transfers oxygen throughout the system. The oxygen, which is dissolved in the water, provides an environment conducive to the growth of aerobic bacteria. These bacteria effectively consume the organic materials. Consider your MULTI-FLO a living organism and treat it as such.

Another feature is the filter "socks," which are suspended in the tank. The "socks" support additional bacteria and strain all effluent before it leaves the unit. Solids are retained in the system. There is no by-pass for solids.

IMPORTANT ITEMS TO REMEMBER

MULTI-FLO units have an initial break-in period of six-to-eight weeks, during which time bacteria establish themselves in the unit. The development of these biological colonies occur naturally with the addition of sanitary wastes, so we recommend you use all your plumbing facilities in a normal manner from initial start-up. You may notice a tendency for the unit to foam from laundry wastes during this period. This is normal, and it should cease by the sixth week. You can help by using moderate amounts of low-sudsing biodegradable detergents.

MULTI-FLO units are designed to treat typical domestic wastewater. Flows from and materials in garage catch basins, storm water drains, sumps, and the like will adversely affect MULTI-FLO operation. Excessive amounts of cleaners, solvents, paints, greases, etc., will lead to a failure and service calls.

The following of these simple rules will decrease or eliminate maintenance problems and prolong the life and efficiency of your unit.

- Maintain a service agreement with an authorized MULTI-FLO service provider.
- Check that your unit's access lid is securely tightened down.
- Check the alarm by pressing the button to activate the light and buzzer on the audio-visual alarm.

- Call your service provider at the first sign of trouble.
- Follow your service provider's advice. He/she is trained to ensure that your unit operates at its maximum efficiency.
- Use low-sudsing, low phosphate biodegradable detergents.
- Contact your service provider if the system is to be used intermittently or if extended periods of non-use is anticipated.
- Keep un-disposable items out of your system. Some examples include but are not limited to: wet strength paper towels, disposable baby diapers, sanitary napkins, rubber and plastic products, rags, grit, and coffee grounds.
- Avoid discharging a water softener backwash into the system.
- Avoid placing grease into your system. Excessive grease will bind the filter socks.
- Do not pour solvents, paints, etc., into your system. These substances will harm the bacteria and plug the filters.
- Always keep your aerator running unless instructed otherwise by your service provider.
- Do not service the unit yourself. Contact your service provider to maintain your MULTI-FLO unit.

ALARM SYSTEM and ALARM CONDITION

Every MULTI-FLO unit comes equipped with an audio-visual alarm system. This alarm should be mounted in a conspicuous location. If an abnormal condition develops, you will be notified with a light and buzzer. Silence the buzzer by pressing the "silence" button on the alarm. If the light should stay on, call your service provider.

Check your audio-visual alarm periodically by holding the "test" button for approximately 10-to-12 seconds or until the light flashes and the buzzer sounds. Push the "Silence" button. Contact your service provider if your "test" button fails to activate the alarm.

If your alarm goes off, there are several steps you can take to determine the possible nature of the malfunction.

1. Is the alarm activated during a non-flow period, i.e., late at night, early morning? If so, the probable cause is the aerator.
2. Is the alarm activated intermittently while washing clothes or taking a shower? If so, filter failure (1–2 weeks) may be impending.

MAINTENANCE PROGRAM

YOUR MULTI-FLO UNIT REQUIRES PERIODIC SERVICING.

Maintenance of your MULTI-FLO is essential to ensure its proper operation and longevity.

During your initial two-year warranty, an authorized service representative will inspect your unit at six-month intervals and make any necessary adjustments to the system. The only exception is for the replacement of “out of warranty” and “physically abused” parts or abuse to the treatment process. Moreover, this warranty will not cover other treatment and dispersal components and devices, such as pre-tanks, drain fields, pump stations, and the like.

For continued service, your service provider will offer an annual service contract at the end of the warranty. Please contact your service provider for details.

In the event a problem arises or service is required, refer to the unit’s data plate (located on the alarm and access lid) or the service label for instructions on contacting your closest service provider. Occasional pumping is required, due to accumulation of solids. The pumping cost may not be covered under your maintenance and service program. If you need parts or service, please contact the factory for the name of the service provider nearest you.

Your MULTI-FLO system is designed and intended to treat typical domestic wastewater (i.e., human bodily waste and liquid waste generated by the occupants of dwellings). To insure optimum performance and longevity, do not discharge any type of non-residential wastewater or other high-strength waste, including commercial food service waste, without contacting the manufacturer to determine if this will be acceptable without additional treatment.

IMPORTANT: MULTI-FLO units must be installed and maintained in compliance with all state and local laws and regulations. This includes compliance with all regulations concerning proper effluent disposal and the pumping and disposal of solids and byproducts pumped from the unit.

MULTI-FLO WARRANTY DOES NOT COVER THE COST OF SERVICE CALLS, LABOR, OR MATERIALS REQUIRED DUE TO THE FOLLOWING:

1. Misuse, abuse, or any repair or alteration performed by anyone other than authorized MULTI-FLO personnel
2. Use of components other than authorized MULTI-FLO replacement components.
3. Non-wastewater flows caused by infiltration, storm water connections, leakage from improperly maintained plumbing fixtures, water softener backwash, etc.
4. Failure to maintain electrical power to the treatment system in accordance with the requirements of the Manufacturer or the authorized MULTI-FLO service provider.

5. Disposal into the MULTI-FLO of non-biodegradable materials (i.e., plastics, coffee grounds, etc.) chemicals, solvents, grease, oil, paint, or any other substance, including but not limited to medicines, metals, toxins, volatile substances, and the like that are deleterious to the development and maintenance of the biological treatment process.
6. Short-term or daily wastewater flows to the MULTI-FLO that exceeds the unit's hydraulic or organic design capabilities.
7. Any usage contrary to MULTI-FLO owner's manual and/or the MULTI-FLO representative's recommendations.

MULTI-FLO MODEL SPECIFICATIONS

Item	FTB 0.5	FTB 0.6	FTB 0.75	FTB 1.0	FTB 1.5
Treatment (gal/day)	500	600	750	1000	1500
Volume (gal)	500	600	750	1000	1500
CBOD (lb/day)	1.5	1.5	1.5	3.0	4.5
Diameter (in)	63"	71"	71"	78"	135"x63"
Total Height (in)	86"	86"	90 ¾"	93"	86"
Grade to Inlet Invert (in)	17 ¾"	16 ½"	16"	14 ¾"	17 ¾"
Grade to Outlet Invert (in)	21"	20"	19 ½"	18 ½"	21"
Excavation Depth (in)	75 ¾"	74 ½"	78 ½"	82 ¾"	75 ¾"
No. of Aerators	1	1	1	2	3
No. of Filters	30	30	30	30	60
Shipping Weight (lb)	380	420	450	580	920
Inlet Invert* (in)	58"	58"	62 ½"	68"	58"
Outlet Invert* (in)	54 ¾"	54 ½"	59"	64 ¼"	54 ¾"
* From Bottom of Excavation – See Drawing					

MULTI-FLO WASTEWATER SYSTEM SPECIFICATIONS

Wastewater Treatment Performance (ANSI/NSF Standard 40 Evaluation)

TEST RESULTS (Mean Results)	INFLUENT (mg/L)	EFFLUENT (mg/L)	REDUCTION (%)
CBOD ₅	150	5	97
TSS	195	5	98

MULTI-FLO COMPONENTS AND SPECIFICATIONS

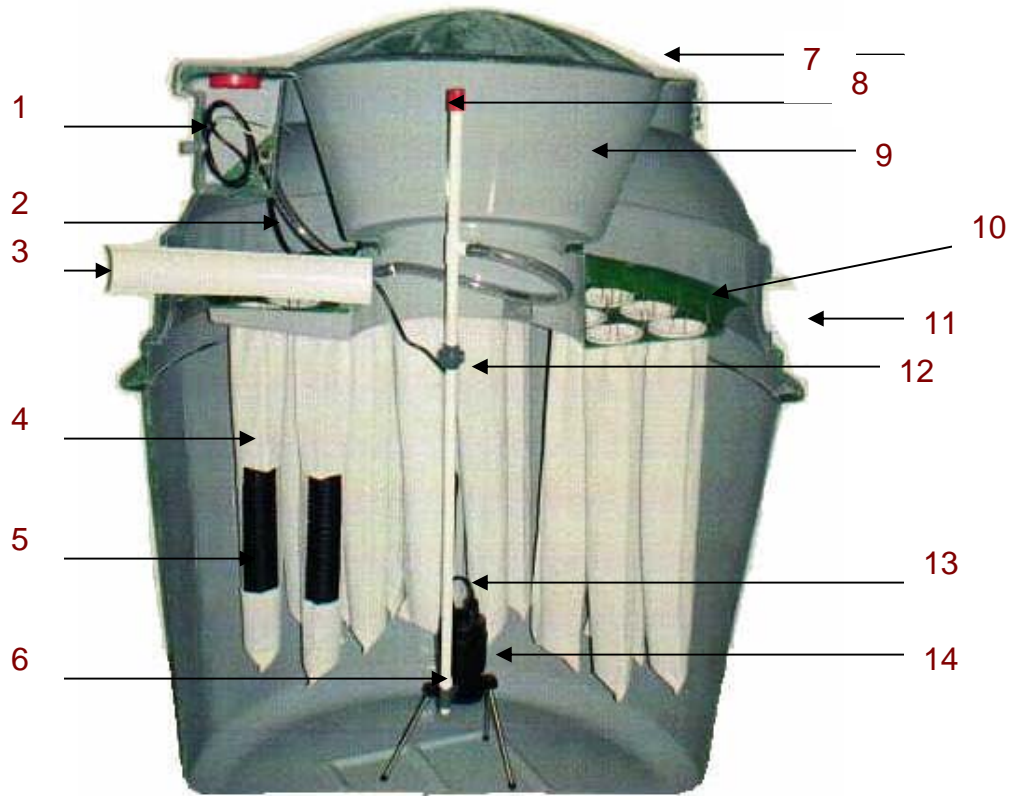

Item	Part No.	Description	Qty.
1	A5037	Junction Box & Junction Box Cover	1
2	A9510	Air Tubing from sensor	1
3	A5025	Inlet Pipe	1
4	B5017	Filter	30
5	W49104L	Expander	30
6	A3016	Air Intake Assy.	1
7	A3008	Access Cover Assy.	1
8	A6517	Primary Alarm Sensor Assy.	1
9	A5029	Surge Bowl	1
10	A6002	Spring Ring Retainers	60
11	A5026	Outlet Pipe	1
12	A9516	3/4" Union	1
13	A6603-4	Aerator Power Cord	1
14	A10031	Aerator	1

WARRANTY

Consolidated Treatment Systems, Inc., warrants the parts in each aerobic treatment unit to be free from defects in material and workmanship for a period of two (2) years from date of installation for treatment of household wastewater when properly registered with the manufacturer. Consolidated Treatment Systems, Inc., sole obligation under this warranty is as follows: Consolidated Treatment Systems, Inc., shall fulfill this warranty by repairing or exchanging any component part, FOB Factory, that shows evidence of defects, provided said component part has been paid for and is returned through an authorized dealer, transportation prepaid. The warrantee must also notify Consolidated Treatment Systems, Inc., of the defect complained of. There is no informal dispute settlement mechanism available under this LIMITED WARRANTY.

No warranty is made as to the field performance of any unit. This LIMITED WARRANTY applies only to the parts manufactured by Consolidated Treatment Systems, Inc., does not include any portion of the household plumbing, drainage, or installation of disposal system. Components or accessories supplied by Consolidated Treatment Systems, Inc., but manufactured by others, are warranted only to the extent of and by the terms and conditions of the original manufacturer's warranty. In no event shall Consolidated Treatment Systems, Inc., be responsible for delay or damages of any kind or character resulting from, or caused directly or indirectly by, defective components or materials manufactured by others.

Recommendations for special applications will be based on the best available experience of Consolidated Treatment Systems, Inc., and published industry information. Such recommendations do not constitute a warranty of satisfactory performance.

This LIMITED WARRANTY extends to the consumer of the product. As used herein, "consumer" is defined as the purchaser who first uses the unit or the subsequent user(s) for the first 2 years after its initial installation. It is the first user's or servicing dealer's obligation to make known to the subsequent user(s) the terms and conditions of this warranty.

This warranty is a LIMITED WARRANTY and no claim of any nature shall be made against Consolidated Treatment Systems, Inc., unless and until the consumer, or his legal representative, notifies Consolidated Treatment Systems, Inc., in writing of the defect complained of and delivers the product and/or defective part(s), freight prepaid, to the factory or an authorized service station.

Consolidated Treatment Systems, Inc., reserves the right to revise, change, or modify the construction and design of the aerobic treatment units for household wastewater, or any component part or parts thereof, without incurring any obligation to make such changes or modifications in equipment previously sold. Consolidated Treatment Systems, Inc., also reserves the right, in making replacements of component parts under this warranty, to furnish a component part which, in its judgment, is equivalent to the part replaced.

UNDER NO CIRCUMSTANCES WILL CONSOLIDATED TREATMENT SYSTEMS, INC., BE RESPONSIBLE TO THE WARRANTEE FOR ANY OTHER INCIDENTAL OR CONSEQUENTIAL DAMAGES, INCLUDING BUT NOT LIMITED TO LOST PROFITS, LOST INCOME, LABOR CHANGES, DELAYS IN PRODUCTION AND/OR IDLE PRODUCTION, WHICH DAMAGES ARE CAUSED BY A DEFECT IN MATERIAL AND/OR WORKMANSHIP IN ITS PRODUCT OR PARTS. SOME STATES DO NOT ALLOW THE EXCLUSION OR LIMITATION OF INCIDENTAL OR CONSEQUENTIAL DAMAGES SO THE ABOVE LIMITATION OR EXCLUSION MAY NOT APPLY TO YOU.

THIS WARRANTY IS EXPRESSLY IN LIEU OF ANY OTHER EXPRESS OR IMPLIED WARRANTY, INCLUDING ANY WARRANTY OF MERCHANTABILITY OR FITNESS, AND OF ANY OTHER OBLIGATION ON THE PART OF CONSOLIDATED TREATMENT SYSTEMS, INC. SOME STATES DO NOT ALLOW LIMITATIONS ON HOW LONG AN IMPLIED WARRANTY LASTS, SO THE ABOVE LIMITATION MAY NOT APPLY TO YOU. THIS WARRANTY GIVES YOU SPECIAL LEGAL RIGHTS AND YOU MAY HAVE OTHER RIGHTS, WHICH VARY FROM STATE TO STATE.

Consolidated Treatment Systems, Inc.
1501 Commerce Center Drive
Franklin, Ohio 45005
Tel: (937) 746-2727
Fax: (937) 746-1446
www.multi-flo.com

MULTI-FLO

WASTEWATER TREATMENT SYSTEMS

PROCEDURES FOR ASSEMBLY AND INSTALLATION

**A Division of Consolidated Treatment Systems, Inc.
1501 Commerce Center Drive
Franklin, OH 45005
Tel: 937-746-2727
Fax: 937-746-1446
www.multi-flo.com**

MULTI-FLO TANK COMPONENTS

Fig. 1.1

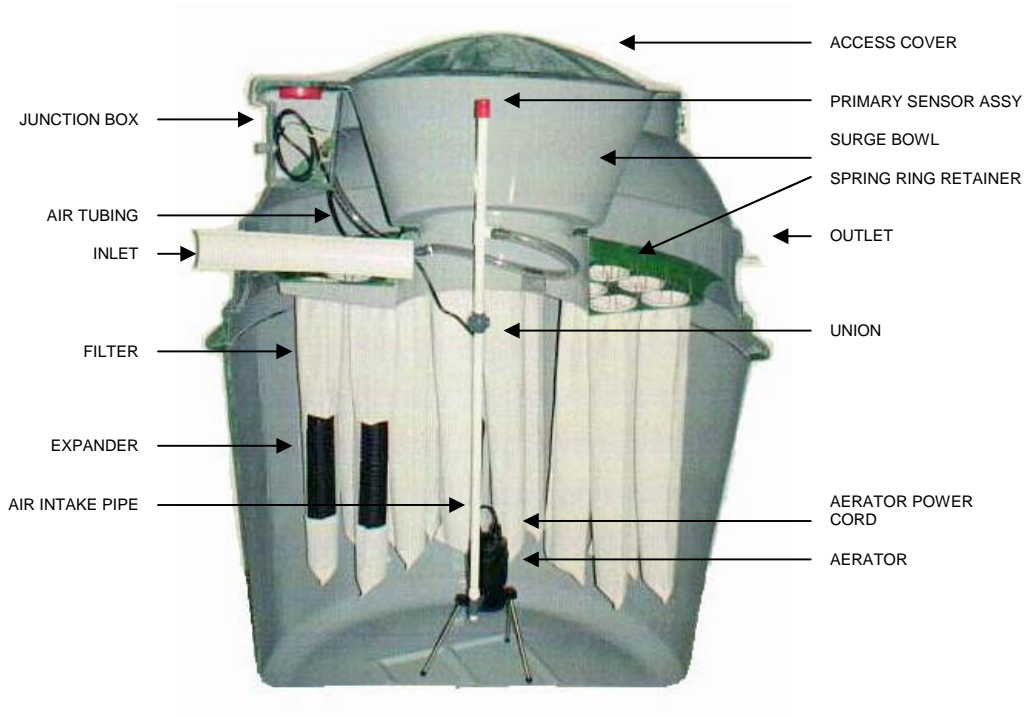

TYPICAL INSTALLATION (Cross Section)

Fig. 1.2

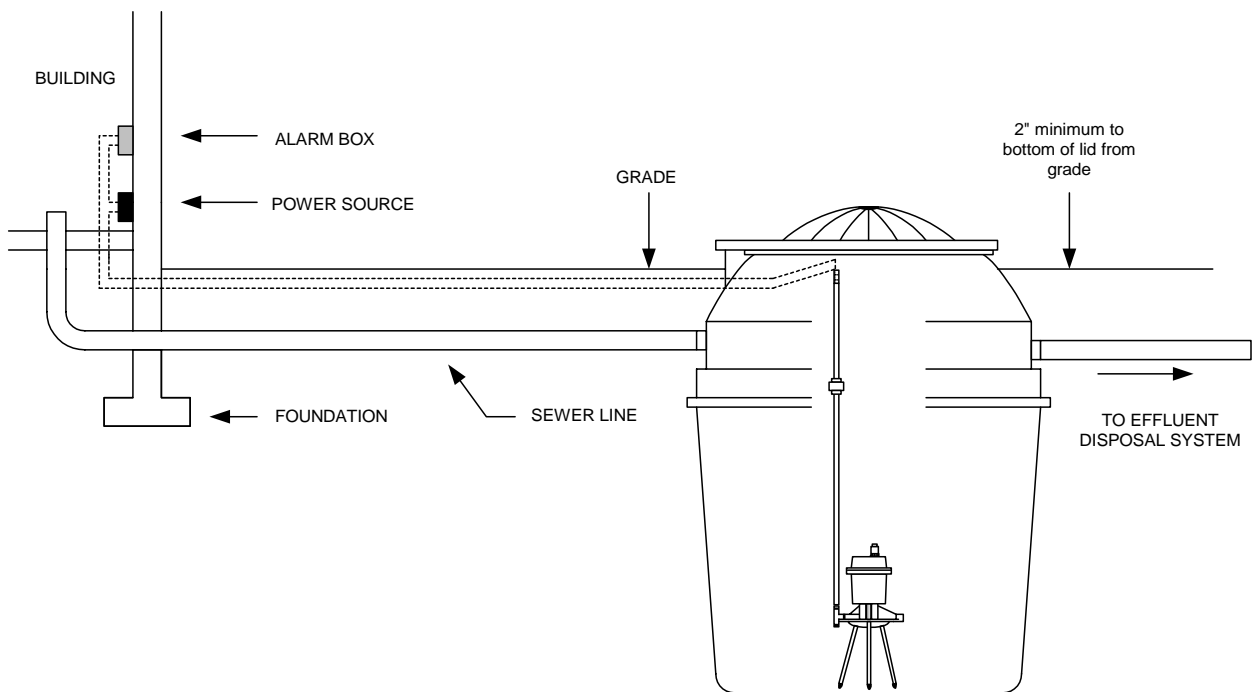

MULTI-FLO
Procedures for
Assembly and Installation

Unless otherwise noted, the instructions within this manual may be used for all models (FTB 0.5, FTB 0.6, FTB 0.75, FTB 1.0 and FTB 1.5) of the **MULTI-FLO** wastewater treatment unit.

The installation must comply with state and local regulations

SECTION 1.0 SITE PREPARATION

1.10 LOCATION

1.11 **An accurate, detailed site plan is essential for successful installation of *MULTI-FLO* units.** The site plan should show the locations and elevations of the wastewater treatment unit and effluent disposal system. Check to make sure the site plan accurately reflects the conditions actually existing at the site and that all required set-backs (i.e., to property lines, wells, etc.) are being met.

1.20 GRADE AND GROUND CONTOUR

1.21 Position the wastewater treatment unit in accordance with the plan. Confirm the accuracy of the elevations shown in the plan.

SURFACE WATER MUST NOT ENTER THE SYSTEM AROUND THE ACCESS COVER OR FROM THE DISCHARGE PIPE.

1.30 COVER EXPOSURE

1.31 The access cover must be exposed at all times to permit the system to function properly and to allow for routine maintenance. There should be a minimum of two (2) inches between the bottom of the lid and the finished grade (refer to Fig. 1.2).

1.40 BUILDING SEWER LINE

1.41 Make sure that the sewer pipe from the building has the proper slope to meet the inlet invert of the **MULTI-FLO** and maintain the grade requirements for the exposure of the cover.

1.50 EXCAVATION PREPARATION

1.51 Mark off an area at least one foot larger than the dimensions of the **MULTI-FLO** and maintain the grade requirements for the exposure of the cover.

1.60 EXCAVATION (refer to Fig. 1.3)

1.61 Prepare the excavation. The opening should follow the area laid out in Section 1.51. Determine the required depth of the excavation based upon the elevation of the invert of the inlet sewer line (B) or the elevation of the finished grade (D), both of which should conform with the site plan. These dimensions are given for each model in Figure 1.3. NOTE: If the distance from the finish grade elevation to the bottom of the excavation exceeds the dimension (D) shown in Figure 1.3, a riser will be required (refer to Section 2.40). If digging in soil containing large rocks or clods of dirt, it may be necessary to remove an extra 6" to allow for bedding material (refer to Item 1.63).

MULTI-FLO TANK DIMENSIONS

Fig. 1.3

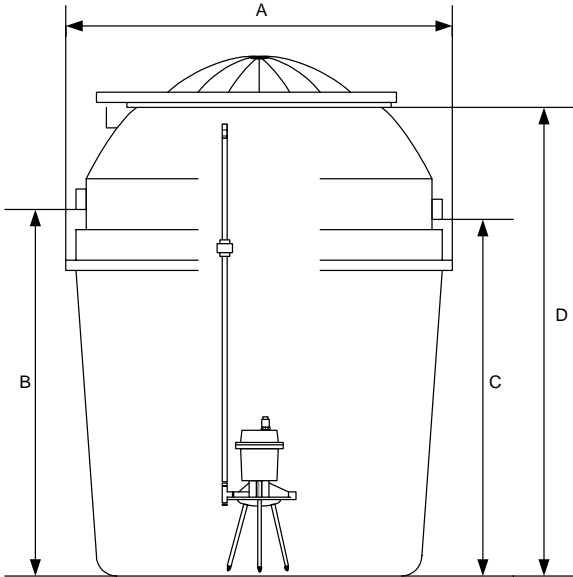

MODEL NUMBERS	DIMENSIONS			
	A	B	C	D
FTB 0.5	63	58	56	76
FTB 0.6	71	58	56	75
FTB 0.75	71	65	63	79
FTB 1.0	78	65	63	83
FTB 1.5	135 x 63	58	56	76

- A = OUTSIDE DIAMETER
- B = INLET INVERT FROM BOTTOM OF EXCAVATION
- C = OUTLET INVERT FROM BOTTOM OF EXCAVATION
- D = FINAL GRADE FROM BOTTOM OF EXCAVATION

1.62 Level the floor of the excavation.

1.63 If bedding material is required, place at least six inches of sand, pea gravel or other similar, suitable granular material on the bottom and smooth out evenly. If ground water is present, use pea gravel or class 2 river rock to build a base for the system. In all cases, the bottom should be level and well compacted. **Note: Localized soil and groundwater conditions may require specialized procedures to assure proper installation.**

SECTION 2.0 INSTALLATION OF THE TANK

2.10 PLACING THE WASTEWATER TREATMENT UNIT INTO THE EXCAVATION
(Refer to Fig. 2.1)

2.11 Rig the tank to lift. See unit specifications for actual weights. Except for the FTB 1.5, ropes can be attached to the inlet and outlet. Note: The FTB 1.5 has lifting hooks that must be used.

2.12 Slowly lower the tank into the hole, setting it carefully on the bottom.

2.13 Position the unit, so that the inlet (higher four inch pipe) is aligned with the sewer line from the building. (See Fig. 1.3)

BACKFILLING PROCEDURES

Fig. 2.1

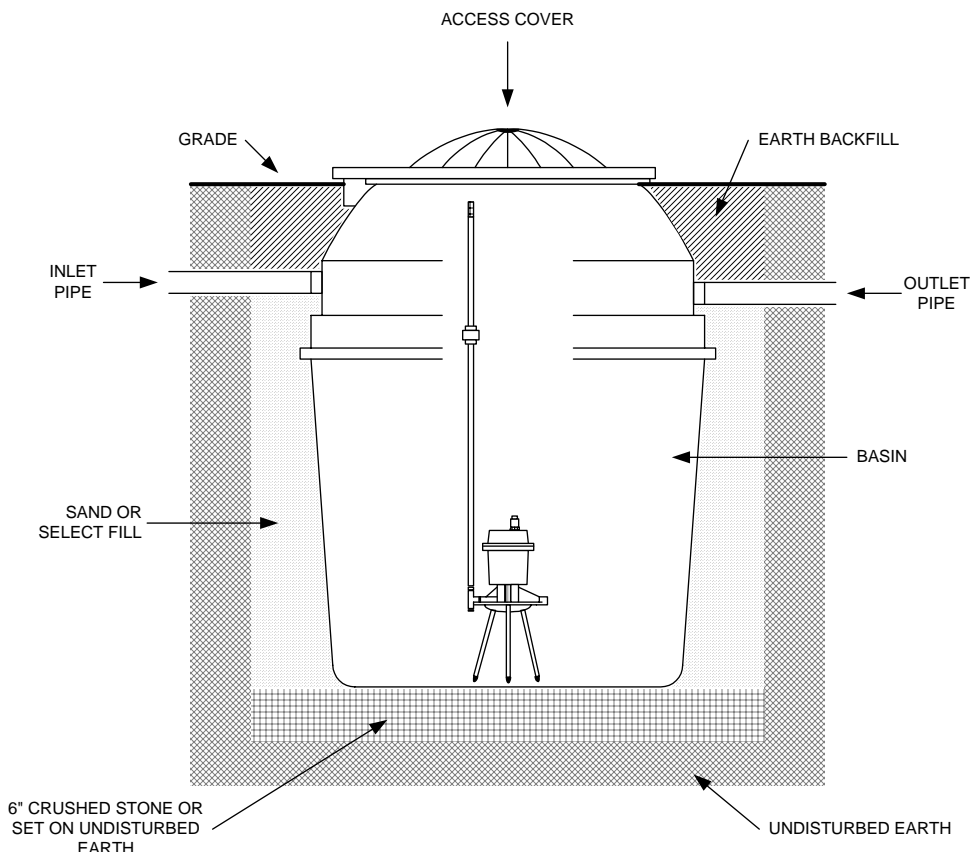

2.20 LEVELING THE WASTEWATER TREATMENT UNIT

CAUTION: The system must be level. A tilted system will not work.

2.21 Place a level across the center tower in several directions. Adjust the tank until it is level. Leveling can be accomplished by shifting the bedding materials. Bedding materials must be evenly distributed to support the weight of the filled tank. **DO NOT USE WEDGES OR OTHER DEVICES TO LEVEL THE TANK.**

2.22 An alternative to using a mechanical level is to plug the outlet pipe with a four inch plastic pipe cap. Fill the area outside of the circular weir with water. As noted in 2.21, adjust the unit until it is perfectly level.

2.30 FILLING THE TANK WITH WATER

CAUTION: To avoid damage from floatation always fill the tank.

2.31 Fill the tank with clean water. Do not fill with water from a pond, river or ground water in the excavation because this water will contain silt or sediment.

2.32 While filling, check frequently to make certain that the tank remains level. If the tank shifts or seems to settle unevenly, discontinue filling and make the necessary corrections to level the tank.

2.33 When the water begins to flow over the weir, stop filling the tank.

2.40 BACKFILLING THE TANK (Fig. 2.1)

2.41 Once the tank has been leveled and has been filled with at least two (2) feet of water, backfilling can begin.

2.42 Using sand, pea gravel or other selected fine material carefully begin backfilling (by hand) until there is approximately 2-3' of compacted fill around the tank.

2.43 After checking the tank to insure it is level, place the access lid on the tank and carefully backfill to the bottom of the outlet pipe. Care should be taken with the backfilling procedures to prevent damaging the tank with rocks or clods of dirt, especially if the original soil is used for backfilling.

2.44 Glue and firmly insert the inlet and outlet sewer pipes (4" Sch. 40 PVC) into their respective fittings. **CAUTION: To prevent any damage to the inlet or outlet pipes due to settling or backfilling, make sure that both the inlet and outlet pipes are set on undisturbed or firmly packed fill material prior to final backfilling.**

2.45 Finish backfilling to a level approximately 2 inches below the access lid. When landscaping is completed, the access lid should be at, or above, finished grade level.

2.46 If the final elevation of the **MULTI-FLO** is below grade so that surface water can enter the access opening of the plant, (1) a dosing pump can be installed prior to the **MULTI-FLO**; or (2) a riser (not exceeding 20") can be provided on the **MULTI-FLO**. **CAUTION: The addition of a riser will make access for service more difficult.**

2.50 INSTALLATION OF FILTER BAGS AND EXPANDERS

2.51 Carefully place an expander into the bag and slide it to the bottom. Be careful not to rip or tear the bag. Even the smallest opening will cause the unit to malfunction.

2.52 Insert the closed end of the filter bag into one of the holes in the hanger plate.

2.53 Continue this process until all filters and expanders are installed. All holes in the hanger plate must have a filter and an expander.

2.60 INSTALLATION OF SPRING FASTENERS

2.61 All filters and expanders must be installed.

2.62 Grasp the spring fastener. (See Fig. 2.2)

2.63 Squeeze the arms of the fastener together until it will slip into the filter bag up to the grooves. (See Fig. 2.3)

2.64 Release the spring, so that the top of the groove in the fastener is on top of the ring that is inside the filter. The bottom of the groove should be in contact with the underside of the hanger plate. The fastener is now holding the filter to the hanger plate. (See Fig. 2.4)

2.65 Place a second spring fastener in the filter at a right angle, so that it lies across the first fastener.

2.66 Continue until each filter has two fasteners in place.

SPRING FASTENERS INSTALLATION

Fig. 2.2



Fig. 2.3



Fig. 2.4



2.70 AERATOR ASSEMBLY AND INSTALLATION

- 2.71 Remove all parts of the aerator from the box. This should include: aerator, legs (3), tee, 1/2" plug, 1/2" nipple, and the owner's manual.
- 2.72 Screw the three (3) legs into the angular threaded holes in the bottom of the aerator cross-shaped piece. Make sure the leg is screwed all the way into the cross.
- 2.73 A plastic cap should be on the plain end of each leg.
- 2.74 Turn the aerator on its side and spin the impeller by hand several times. **THIS STEP IS IMPORTANT.**
- 2.75 With the aerator in the position shown (See Fig. 2.5) assemble the plastic tee to the nipple on the aerator.
- 2.76 Screw the one-half inch plug into the bottom of the tee.
- 2.77 Screw the threaded end of the air intake pipe into the top of the tee.

AERATOR ASSEMBLY

Fig. 2.5

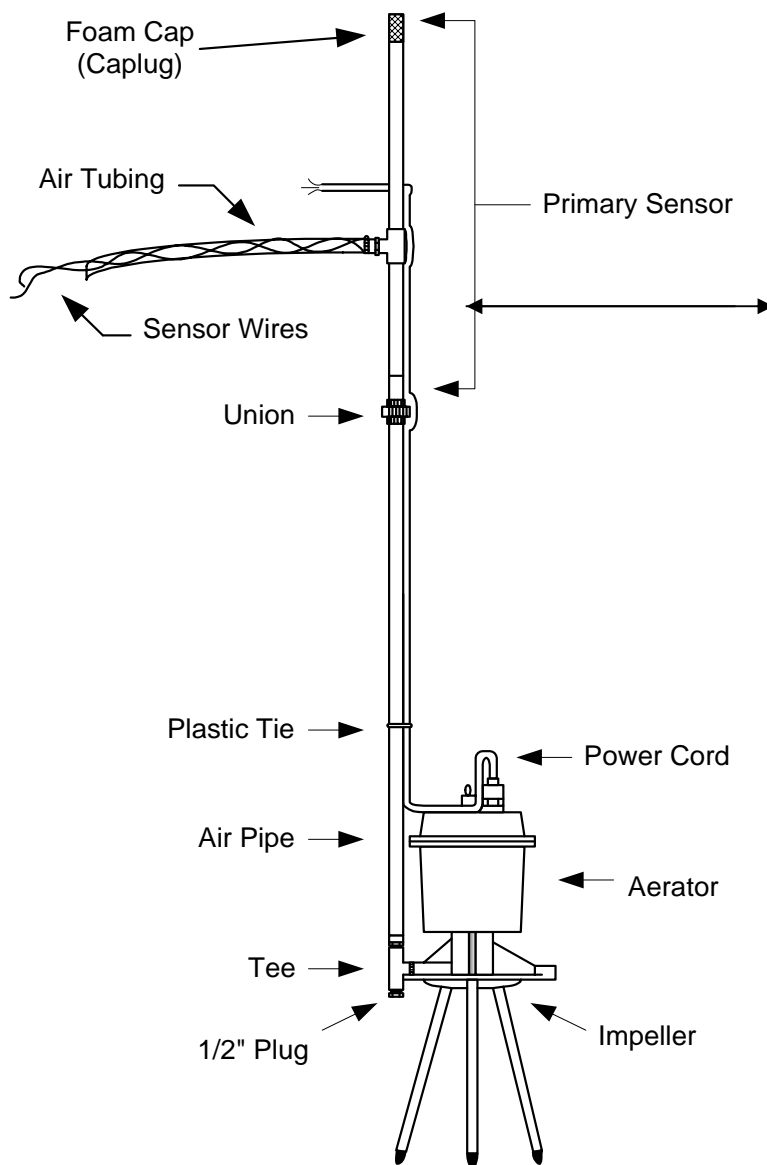

- 2.78 Attach the sensor assembly (Fig. 2.6) with the union to the air intake pipe. Tighten as much as possible by hand. **NOTE:** Be sure that the O ring seal is in the union half of the assembly.
- 2.79 Tie the aerator power cord to the air intake pipe with the plastic ties. **CAUTION: Do not pull or stretch the power cord. To facilitate removal, a nylon rope or chain can be attached to the lifting ring on the top of the aerator.**
- 2.80 By grasping the air intake pipe, carefully lower the aerator assembly through the center of the tank opening to the bottom. **CAUTION: Be sure to keep the air tubing from crimping which will prevent air flow.**

SENSOR ASSEMBLY

Fig. 2.6

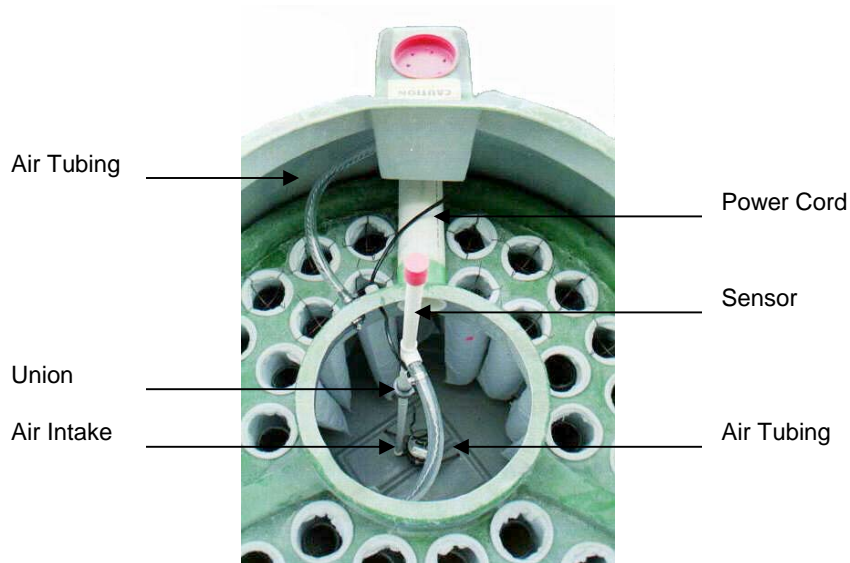

- 2.81 Run the aerator power cord through the fittings as shown in figure 2.6 and into the junction box. **CAUTION: Use care when running the power cord through the fittings. Damage to the cord will void the warranty.**

SECTION 3.0 ELECTRICAL CONNECTIONS (ALARM AND AERATOR) (Refer to specific sheet of direction for each model)

SECTION 4.0 START-UP PROCEDURES

4.10 CHECKING THE AERATOR

- 4.11 Once the aerator and alarm have been installed, and all electrical work is completed, power should be supplied to the aerator and alarm.
- 4.12 Check the aerator to insure proper operation. If no air bubbles are observed coming from the aerator, immediately disconnect the power source. Refer to Items 1A, 1B, and 1C of the Trouble-Shooting Checklist for corrective action.

4.20 CHECKING THE FILTERS

4.21 Once the aerator is running, check each filter to see if any air bubbles are escaping under the filter ring. If so, remove the clips, re-adjust the filter and re-install the clips. Some adjustment may be necessary to eliminate the bubbles.

4.30 CHECKING THE ALARM

4.31 With the power being supplied to the aerator and alarm, press the “test” button to activate the alarm. Note: YOU MUST HOLD THE TEST BUTTON DOWN FOR 6-to-7 SECONDS BEFORE THE ALARM ACTIVATES.

4.32 Shut the power off to the aerator and check if the alarm is activated. Again, allow 6-to-7 seconds for the alarm to sound.

4.33 If the alarm is not activated during these tests, refer to Items IIA and IIC of the Trouble-Shooting Checklist for corrective action.

4.34 If the alarm activates after 10-15 minutes of operation, reverse the white and black sensor wires in the alarm.

4.40 UNIT START-UP

4.41 Once the aerator and alarm have been checked and are operational, the unit is ready to receive sewage flows.

4.42 Normally, it is not necessary to add any chemicals or enzymes to facilitate unit start-up. It is helpful, however, to restrict the discharge of excessive amounts of gray water from showers and laundry during the initial 6-to-8 weeks of use.

4.43 If the **MULTI-FLO** system exhibits a gray dishwater appearance in the aeration chamber, or has a noticeable odor, contact the factory or the local authorized representative for the proper procedure to follow to attain normal operation.

SECTION 5.0 USE OF A PRETREATMENT TANK (Fig. 5.1)

MULTI-FLO has been designed and certified to function without the use of pre-treatment tank. However, installation of a pre-treatment tank, if used to address local requirements or to reduce maintenance problems, will not adversely affect unit performance if it is properly sized and installed.

If a pre-treatment tank is installed, the liquid capacity of the pre-tank should be between 50-to-100 percent of the treatment capacity of the **MULTI-FLO**. Slightly larger tanks can be used with the FTB 0.5 and FTB 0.6. Please refer to the **MULTI-FLO** Design Guide for details.

- 5.11 The use of a pre-tank may cause septic odors to escape from the **MULTI-FLO** during periods of heavy usage (i.e., laundry). In these cases, a 4-inch Schedule 40 elbow can be installed on the inlet pipe to the **MULTI-FLO**. A 12-inch piece of pipe should be added to extend below the surface of the water (refer to Fig. 5.1).

MULTI-FLO INLET DEVICE WHEN INSTALLED AFTER A PRE-TANK

Fig. 5.1

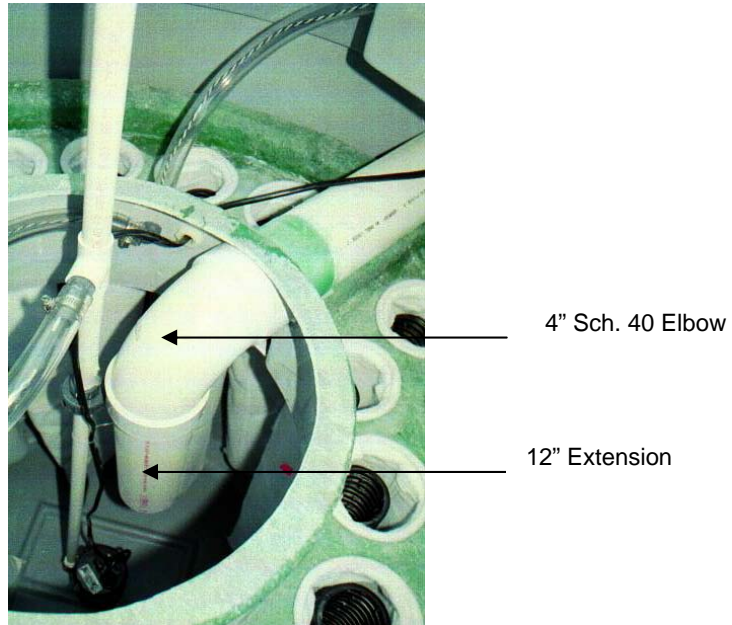

MULTI-FLO

MULTI-FLO WASTEWATER TREATMENT SYSTEMS

DESIGN MANUAL

Revised December 19, 2003

**Consolidated Treatment Systems, Inc.
1501 Commerce Center Drive
Franklin, OH 45005
937-746-2727
www.multi-flo.com**

Multi-Flo -Series Onsite Wastewater Treatment Systems

Introduction

Onsite wastewater treatment refers to the process of treating and disposing, dispersing, or recycling of wastewater at or near its point of generation. Historically, the phrase has been synonymous with “septic system” because that was the only design alternative available. With the advent of different design technologies, septic systems are just one of several available alternatives. Because treated wastewater—effluent—is a valuable resource, owners have the flexibility in how they use this resource. Multi-Flo systems provide owners with options as to how they treat and recycle wastewater.

The suitability and design of septic systems rely upon native soils to treat *and* disperse wastewater. In fact, treatment and dispersal are essentially combined in the same process. For this reason, septic system use is limited to those soils where both functions can be accomplished. Multi-Flo units allow owners to separate treatment and dispersal and address each separately. If soil is the selected dispersal alternative, the design can be based solely upon the ability of the soil to transmit water from the site. Owners may have options, depending on local codes, to use the treated wastewater for beneficial purposes such as recycling into plumbing systems or irrigating gardens and turf. The Multi-Flo series provides owners with alternatives unavailable to those who rely solely upon septic systems.

The Multi-Flo -series are capable of treating typical domestic wastewater daily flows equal to rated capacities, which are shown in Table 1. The Multi-Flo FTB-series design is based on the same principles as many municipal wastewater treatment plants. These design principles have been adapted for the small flows developed by individual residences or small commercial/residential developments.

Model	Rated Flow (gpd)	O ₂ Transfer (Max., lb/day)
FTB-0.5	500	3.6
FTB-0.6	600	3.6
FTB-0.75	750	3.6
FTB-1.0	1000	7.2
FTB-1.5	1500	10.8

This manual serves as a guide to design an onsite wastewater treatment system using Multi-Flo units. The manual includes recommendations for both residential and commercial applications. The recommendations include typical flow data and component suggestions. A failure to consider these recommendations may result in poor unit operation or additional maintenance.

Definitions

The following definitions are critical to understanding the design, installation and operation of Multi-Flo units. These definitions have been purposely simplified so they can be understood by a wide range of readers.

ANSI/NSF Standard 40: A performance certification standard intended for onsite wastewater treatment systems having a flow for between 400 and 1500 gpd (gallons per day) and a single point of discharge.

CBOD₅: The concentration of oxygen (expressed as mg/L) utilized by microorganisms in the non-nitrogenous oxidation of organic matter during a five-day period at a temperature of 20°C.

Clarify: A process of separating from wastewater fats, oils, grease, and floatable materials, which float to the surface; and solids, which sink to the bottom.

Commercial Occupancy: A building used for commerce or industry.

Dispersal: A process for recycling treated wastewater back into the environment.

Dosing: A process for periodic discharge of wastewater to a Multi-Flo unit.

Effluent: The discharge from a treatment component or system.

Flow Equalization: A process for mitigating variations in flow by holding wastewater in a tank and dosing the wastewater into the Multi-Flo unit.

Flow Equalization Tank: A watertight, airtight tank, timer, and pumping system having a detention time of 16-to-24 hours used to capture and retain solids, grit, and scum, and then meter the water into the Multi-Flo unit through periodic dosing.

FOG: Fats, oils, and grease in wastewater.

Frequenter: A visitor to and/or customer of a commercial occupancy.

Grease Trap: A tank for capturing and retaining fats, oil, and grease.

Maintenance: Periodic activities intended to maintain the efficiency and effectiveness of the system.

Mixed Liquor. The contents of the Multi-Flo aeration chamber consisting of, but not limited to, partially treated wastewater and microbial colonies that oxidize the organic material in the wastewater.

Onsite Wastewater Treatment System. A device or combination of devices, which may include tanks, vessels, pumps, aerators, aerators, and other mechanical equipment, intended to treat and disperse wastewater at or near the point of generation.

Pre-aeration: Aeration of wastewater to reduce the CBOD₅ prior to discharge to the Multi-Flo unit.

Pre-Aeration Tank: A tank used to reduce partially the CBOD₅ of the wastewater before the wastewater enters the Multi-Flo unit.

Pretreatment Tank: A watertight, airtight tank having a detention time from 12-to-24 hours used to capture and retain solids, grit, and scum before the wastewater enters the Multi-Flo unit.

Residential Occupancy: A building used to house individuals and families.

Septic System: An onsite wastewater treatment system comprised of a septic tank and soil absorption system.

Septic Tank: A watertight, airtight tank having a detention time of 24-to-48 hours, or more, used to clarify wastewater and capture fats, oil, greases, and inert solids.

Soil Absorption System: A system consisting of trenches and pipes—or equivalent “gravelless” devices—used to disperse water into the soil where additional treatment may occur and the water is dispersed from the site.

Trash Trap: A watertight, airtight tank for capturing and retaining solids.

Seeding: A process for facilitating bacterial growth by providing mixed liquor from another Multi-Flo unit.

TKN (Total Kjeldahl Nitrogen): The quantity of organic nitrogen and ammonia (expressed in mg/L) found in wastewater.

TN: The total quantity of nitrogen (expressed in mg/L-N) that exists in the wastewater. Nitrogen may be in the form of ammonia, TKN, nitrate or nitrite.

TSS: The quantity of solids (expressed in mg/L) that can be readily removed from a well-mixed sample with standard laboratory filtering procedures.

Typical Domestic Wastewater: Wastewater having the characteristics as shown in Table 2:

Constituent	Value
CBOD5	100-300 mg/L
TSS	100-350 mg/L
FOG	30 mg/L
TKN	60 mg/L

Wastewater: Water generated as a result of human activities and containing feces, urine, blood, food byproducts, rinse water, laundry water, process water, and the like.

Design Principles

The goal of wastewater treatment is to return to the environment water that does not pose a public health or environmental threat. The role of the Multi-Flo in this process is to remove organic materials, solids, and pathogens through biological treatment.

Each model of the Multi-Flo FTB-Series has a specific design rating. Each rating is intended to identify the volume of typical domestic wastewater that the system can treat in a 24-hour period. The flow during this 24-hour period, as tested under ANSI/NSF Standard 40, is shown in Table 3.

Time of Day	Percent of Total Hydraulic Load
6:00 AM-9:00 AM	35
11:00 AM-2:00 PM	25
5:00 PM-8:00 PM	40

Additional treatment may be necessary where the flow regime varies from Table 3 and/or the wastewater does not meet the criteria of typical domestic wastewater.

Typical domestic wastewater may include small quantities of medicines, cleaners, antibiotics, and other substances that, in large quantities, will adversely affect the operation of the system. The water will have a pH of approximately 7.0 and may have minute concentrations of heavy metals. If the pH is above 9.0 or less than 6.0, and/or there are high concentrations of harmful substances and heavy metals, additional treatment will be necessary.

Depending on the occupancy, an additional tank may be installed upstream of the Multi-Flo. This additional component may be a "trash trap," "pretreatment tank," "flow equalization tank," or "pre-aeration tank." The name will vary with the intended function of the tank, and the function of the tank is related to its capacity and components. A trash trap is the smallest of these, and its function is simply to capture and retain large solids such as tampons, disposable diapers, and so forth. No additional treatment or function is expected, and the capacity of the tank may be as small as 250 gallons.

A pretreatment tank is larger than a trash trap, and its function is to capture and retain fats, oils, grease, and smaller solids such as dental floss. The capacity of a pretreatment tank is related to the flow from the occupancy. A flow equalization tank serves as a pretreatment tank, but its primary function is to retain wastewater for periodic dosing into the Multi-Flo. A pre-aeration tank is intended to provide additional oxidation. This tank will contain additional aerators to facilitate a partial digestion of organic material prior to its discharge to the Multi-Flo unit. A pre-aeration tank may also serve as a flow equalization tank.

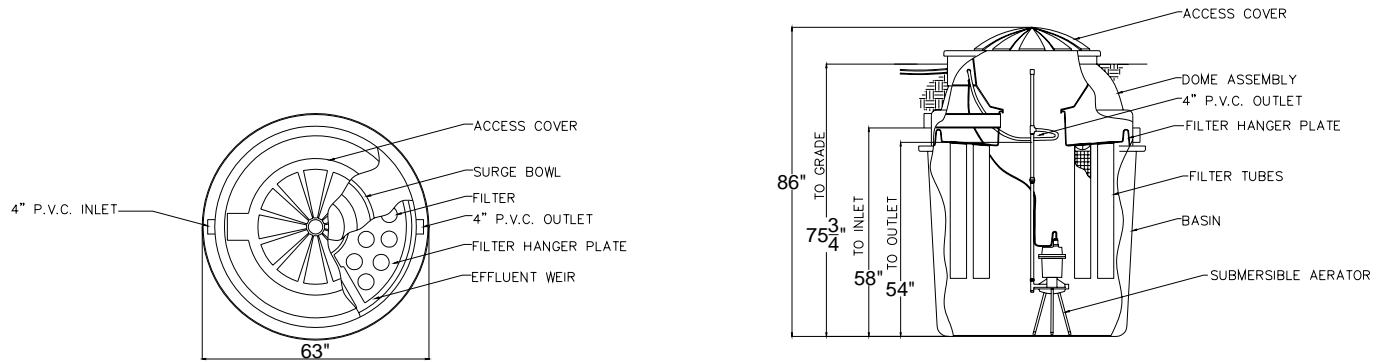

Figure 1—Multi-Flo FTB-0.5

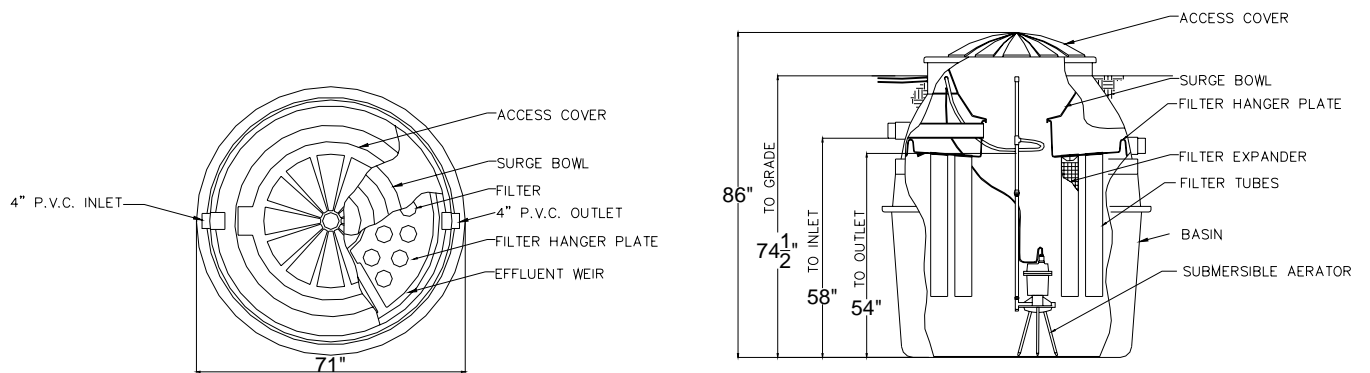

Figure 2—Multi-Flo FTB-0.6

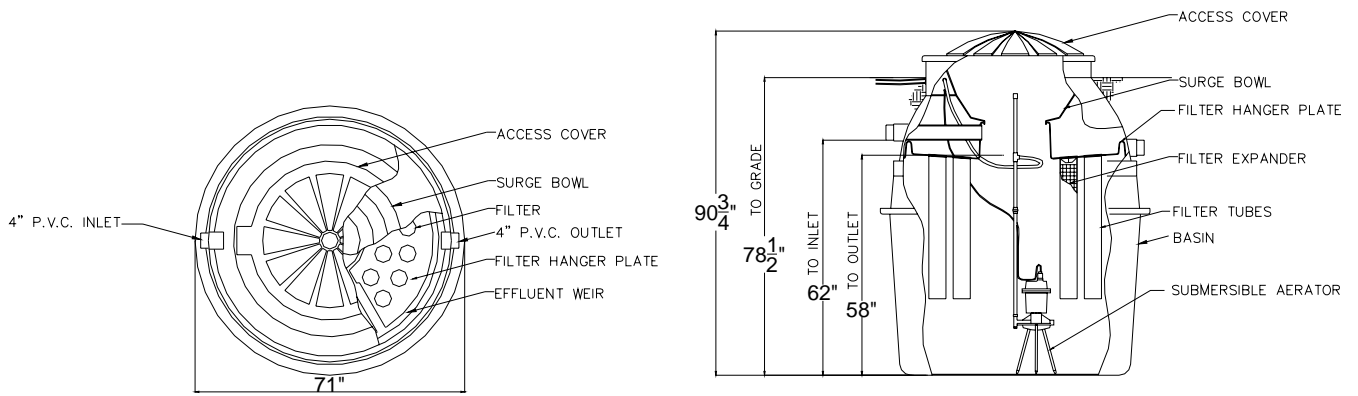

Figure 3—Multi-Flo FTB-0.75

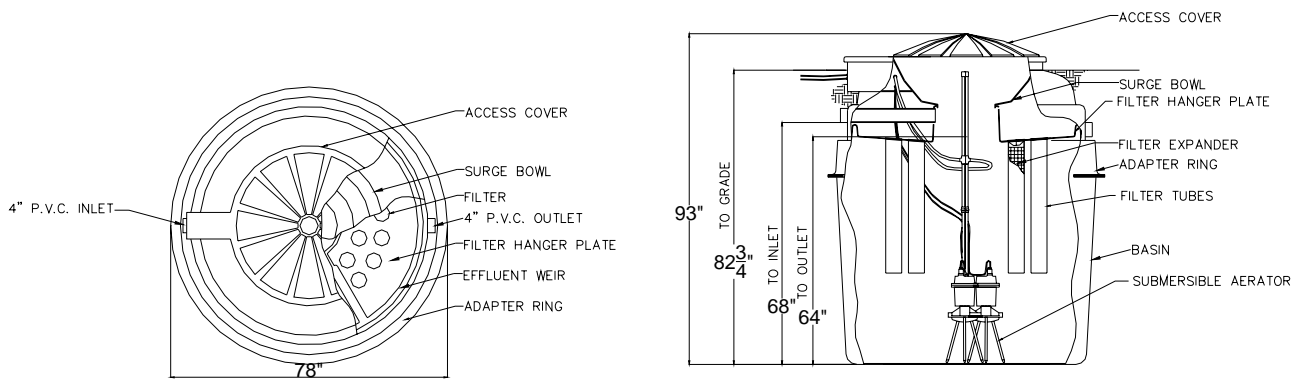

Figure 4—Multi-Flo FTB-1.0

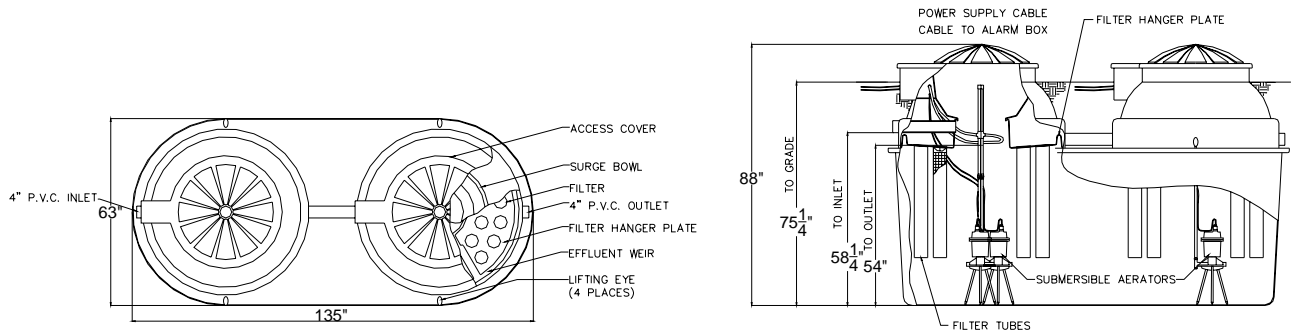

Figure 5—Multi-Flo FTB-1.5

Every county of almost every state regulates the design, installation, operation, and maintenance of onsite wastewater treatment systems. Some counties have few regulations while others maintain comprehensive programs that include licensing, certifications, plan review, and mandatory maintenance. Generally, these regulations mandate residential system sizing, usually based on the number of bedrooms. Commercial occupancies generally use building code parameters to establish design

flow. These parameters are based on number of patrons, square footage of retail space, restaurant seats, and other indicators of potential wastewater generation. Some codes may consider alternative values to establish flow, such as actual water use for similar facilities, but most codes are prescriptive in setting design flows.

Listed in Table 4 are recommended sizing and components for single-family dwellings based on a design flow of 150 gpd/bedroom.

Multi-family occupancies are more susceptible to abuse by tenants, who may be unaware that they are using onsite wastewater treatment. For these occupancies, a pretreatment tank may eliminate maintenance issues related to grease and solids put into the system. Table 5, which is based on a flow of 150 gpd/bedroom, illustrates recommended components, volumes, and ratings for multiple family dwellings.

Number of Bedrooms	Garbage Disposal?	Recommended Size of Pretreatment Tank	Required Capacity of Multi-Flo (gpd)
1-2	No	Optional	500 gpd
1-2	Yes	Optional	500 gpd
3	No	Optional	500 gpd
3	Yes	Optional	500 gpd
4	No	Optional	600 gpd
4	Yes	Optional	600 gpd
5	No	Optional	750 gpd
5	Yes	500 gallon	750 gpd

Number of Bedrooms Served	Recommended Size of Pretreatment Tank if needed, (gal)	Required Capacity of Multi-Flo (gpd)
1	Optional	500
2	500	500
3	500	500
4	500	600
5	500	750
6	750	1000
7	750	1200
8	750	1200
9	750	1500
10	1000	1500

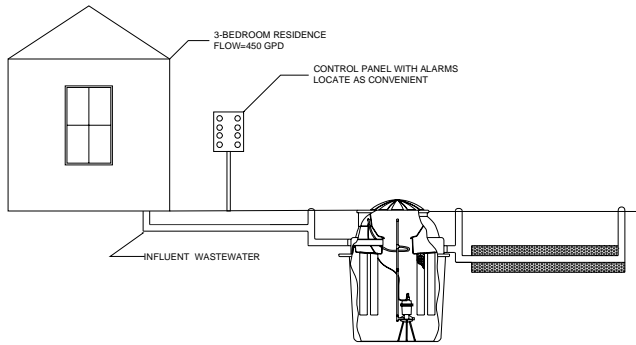

Figure 7 - Basic Multi-Flo Installation

Figure 7 shows a basic installation. In this example, the Multi-Flo FTB-0.5 serves a three-bedroom residence. It receives and discharges flow by gravity. Effluent is dispersed through a drainfield sized in accordance with applicable codes. In this example, the Multi-Flo provides both the storage of a septic tank and wastewater treatment normally associated with the drainfield. The soil acts to “polish” the effluent of residual pathogens, solids, and organic material.

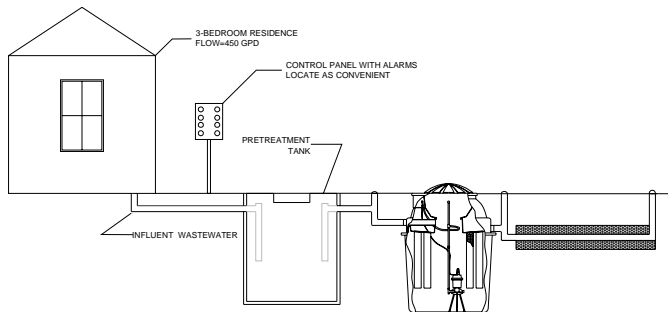

Figure 8 - Multi-Flo Installation With Pre-Treatment

Figure 8 shows a basic Multi-Flo installation with the addition of a pretreatment tank. “Pretreatment” is essential when the wastewater is laden with solids or has other unusual characteristics. Pretreatment accomplishes several functions: capture and storage of solids, homogenization of the wastewater, and partial removal of organic material. Pretreatment may enhance treatment is generally not essential for successful performance.

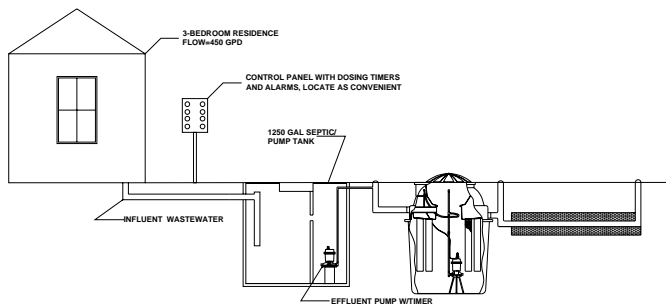

Figure 9 - Multi-Flo Installation With Flow Equalization

Flow equalization may be needed when high variation exists. Such cases arise when much or all of the flow is generated during one or two short periods of a day or week. As an extreme example, flow equalization would help when all wastewater is generated in the morning and evening, there are parties on Friday evenings, and all laundry is washed on Saturdays. Flow equalization provides a method to capture, homogenize, and meter wastewater into the Multi-Flo,

maximizing operational efficiency.

Flow equalization functions by placing a pump on a timer that operates over a 24-hour cycle. The design flow will be divided into 48 or 96 equal doses, each of which will be discharged at 15-to-30 minute intervals, depending on the design. For example, a 500 gpd FTB-0.5 can receive 48 doses of about 10.4 gallons, each dose discharged at 30-minute intervals.

Flow equalization also provides the benefits of pretreatment. As shown in Figure 9, the flow equalization tank is actually a two-compartment septic tank-pump chamber. The septic tank portion acts as a pretreatment tank while the pump chamber holds partially treated water for dosing into the Multi-Flo.

Design Requirements for Commercial Occupancies

Although the Multi-Flo has been used primarily for residential facilities, including both single-family and multiple-family dwellings, Multi-Flo can be effectively used for commercial occupancy including various types of food services. Because of hydraulic surges, grease, use of chemicals and cleaning agents, additional pre-treatment facilities may be required when the Multi-Flo is used for certain types of commercial facilities.

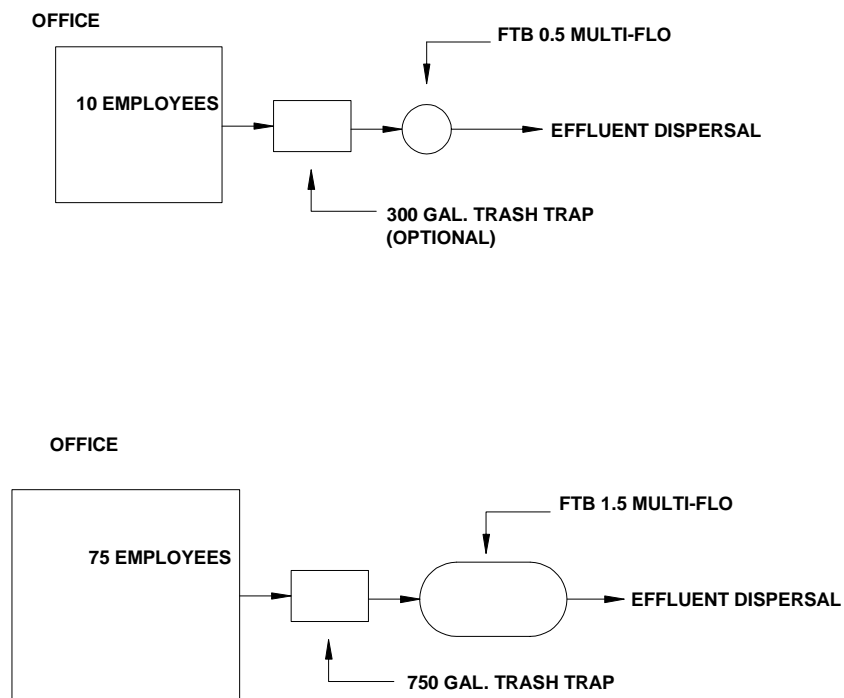

Figure 10—Commercial Occupancy Multi-Flo Installation with Flow Equalization

Design Flow and Loads

Essential to proper design of commercial systems is a characterization of the flow and organic and solids loadings the occupancy will generate. These values may be obtained from several sources. If the facility is existing, meter readings may provide the answers. For new facilities, design values may already be established in plumbing or sanitary codes. Standard engineering texts also provide values. Listed below in Table 6 are typical design values.

Table 6—Wastewater Flow and Organic Load			
Type of Facility	Flow Gal/Unit/Day	CBOD₅ mg/L	CBOD₅ lb/DAY/UNIT
Apartment	150 gal/bedroom	240	.30 lb/bedroom
Assembly Hall (no kitchen)	5 gal/seat	240	.01 lb/seat
Bowling Alley (no kitchen)	75 gal/lane	240	.15 lb/lane
Church (no kitchen)	3 gal/sanctuary seat	240	.01 lb/seat
Country Club	50 gal/member	400	.17 lb/member
Country Club	20 gal/employee	240	.04 lb/employee
Drive-In Theaters	5 gal/car space	240	.01 lb/car space
Employee (no showers)	20 gal/employee	240	.04 lb/employee
Employee (showers)	35 gal/employee	240	.07 lb/employee
Food Service			
Ordinary Restaurant	50 gal/seat	600-800	.35 lb/seat
24-Hour Restaurant	75 gal/seat	600-800	.50 lb/seat
Freeway Restaurant	100 gal/seat	600-800	.70 lb/seat
Tavern (limited food)	30 gal/seat	400	.10 lb/seat
Carry-out (single-service)	50 gal/100 sq.ft./floor sp.	600-800	.70 lb/100 sq.ft./fl. sp.
Carry-out	20 gal/employee (add'l)	240	.04 lb/employee
Fast Food Chain	100 gal/seat	1000	.80 lb/seat
Hospital (not incl. Personnel)	200 gal/bed	400	.70 lb/bed
Hospital personnel (additional)	20 gal/employee	240	.04 lb/employee
Laundry (coin-operated)	400 gal/machine	600	2.00 lb/machine
Mobile Home Park	200 gal/space	240	.40 lb/space
Motel and Hotel, regular	150 gal/room	240	.30 lb/room
Resort hotel, cottage	75 gal/room	240	.15 lb/room
Add for self-service laundry	400 gal/machine	600	2.00 lb/machine
Nursing Home (not incl. Kitchen or laundry)	100 gal/bed	400	.30 lb/bed
Office Building (per 8-hr shift)	20 gal/employee	240	.04 lb/employee
Service Station	250 gal/water closet	240	.50 lb/fixture
Schools			
Day/type	15 gal/student	240	.03 lb/student
Add for showers	5 gal/student	240	.01 lb/student
Add for cafeteria	5 gal/meal	600	.03 lb/meal
Add for school employees	15 gal/employee	240	.03 lb/employee
Boarding school	75 gal/student	240	.15 lb/student
Shopping Center (no food)	100 gal/1000 sq.ft./floor sp	400	.30 lb/1000 sq.ft.fl.sp.

Type of Facility	Flow Gal/Unit/Day	CBOD ₅ mg/L	CBOD ₅ lb/DAY/UNIT
service or laundry)			
Travel Trailer or RV Park			
W/out water/sewer hook-up	75 gal/space	400	.25 lb/space
With water/sewer	100 gal/space	400	.30 lb/space

Four flows must be considered during the design: maximum month average daily flow, minimum monthly average daily flow, peak daily flow, and peak hourly flow. Each of these will be different, and the combination of these flows is essential developing the most efficient design. Typically, the Multi-Flo unit will be sized to treat the maximum month average daily flow. If there are multiple Multi-Flo units operating in parallel, they will be placed into service depending on how the flow varies over a year's time. Flow equalization must be sized to hold the peak daily flow. And if the peak hourly flow is high, flow equalization must be sufficient to hold this additional flow above the peak daily flow.

Ideally, flow should be spread over a 24-hour period. The minimum effective capacity of the treatment tank should be two-thirds the peak daily flow. Churches and meeting halls may have only one or two days each week during which they are in use. Flow equalization may spread the large single-day flows over two or three days, depending on the maximum month average daily flow.

When flow equalization is used, a separate trash trap is generally not needed. For greater efficiency, a two-compartment septic tank should be considered for use as the flow equalization tank

The size and pumping frequency of the pump depends upon the volume of wastewater to be treated. Typically, an 11-gallon dose is given over a five-minute interval. Such low loading minimizes the need for larger pumps. The following table gives recommended pumping frequency and volume/dose:

Flow (gal/day)	Doses/Day	Gal/Dose
250	24	11
500	48	11
750	72	11
1000	96	11
1500	96	16

For food service occupancies, grease traps will also be required. The capacities of these grease traps may be set in local plumbing codes. Generally, the minimum capacity is 750 gallons. When the required capacity exceeds 1000 gallons, two or more tanks located in series should be considered. Only plumbing fixtures located in the kitchen should be connected to the grease trap.

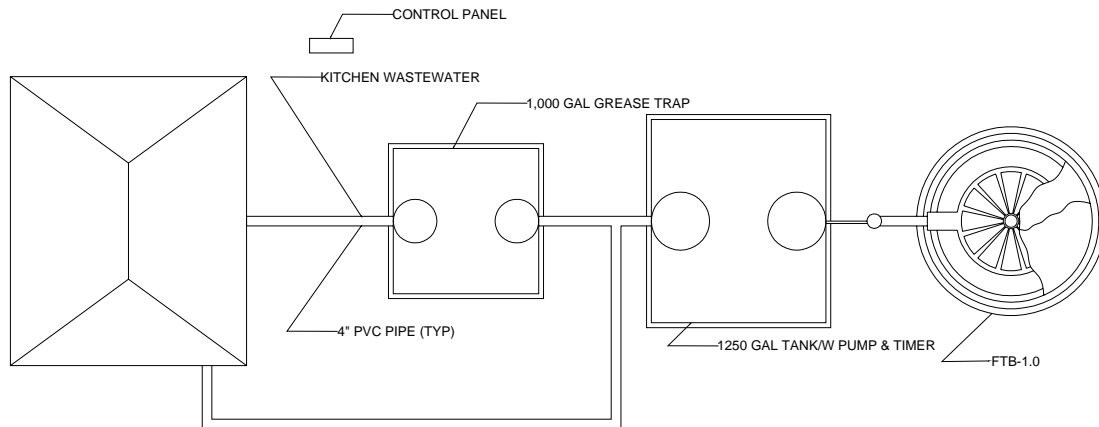

Figure 11—Plan View Showing Grease Trap

Even if flow equalization and a grease trap are not required, a trash trap is recommended to capture fats, oil, grease, and other material from entering the Multi-Flo. Such material includes, but is not limited to, tampons, sanitary napkins, cleansing pads, contraceptives, dental floss, and so forth.

The following recommendations address designs for different applications:

- **Single Family Residence:** A trash trap is optional unless a garbage disposal is installed. If a trash trap is provided, it should have a capacity of 300-to-500 gallons.
- **Rental Housing, Multiple Family or Mobile Home Parks:** A trash trap having a capacity of 50 percent of the average daily flow should be provided.
- **Offices and Public Buildings without Kitchen Facilities:** A small trash trap with a capacity of 25-to-50 percent of the daily average flow should be provided. Although such facilities do not have a grease problem, they do frequently experience problems with paper towels and sanitary napkins. It may be advisable for the owner to use wall-mounted hand dryers or cloth towel dispensers.
- **Gas Stations, Garages or Auto Repair Shops:** A trash trap having a capacity of 50 percent of the average daily flow should be provided. Under no circumstances should wash bays, floor drains or oil separators be connected to the Multi-Flo.
- **Campgrounds:** A trash trap with a capacity of 50 percent of the daily flow should be installed. It is not advisable to discharge the contents of the dump station into the Multi-Flo since there is usually a large amount of bacterial retardants and other chemicals that may kill off the bacteria in the Multi-Flo.
- **Weekend Cottages or Winter Homes:** Facilities with small daily flows, intermittent or seasonal usage should not have a trash trap installed.

- **Restaurants, Hospitals, Nursing Homes or Schools:** Facilities having kitchen and laundry facilities require trash traps or grease traps. Contact your Multi-Flo representative for specific recommendations on the design of systems to serve the above types of facilities.
- **Facilities Served By Two Or More Multi-Flo Plants in Parallel:** Provide a trash trap before a distribution box if the flow is to be split between two or more Multi-Flo units.

The treatment capacity of each Multi-Flo unit is based upon the oxygen requirements necessary to treat typical domestic wastewater. The Multi-Flo aerator is designed to treat a minimum of 1.5 lb-CBOD₅/day. Where wastewater has a higher organic concentration, additional oxidation capacity will be required. Often this additional capacity is provided by adding aeration to the pretreatment tank. For example, foodservice wastewater frequently has a CBOD₅ greater than 1000 mg/L due to soluble grease, cleaning agents, etc. Because of the higher oxygen demand, a longer retention in the aeration stages is required. Pre-aeration meets the additional oxygen requirements. Pre-aeration can usually be accomplished by installing one or more Multi-Flo aerators in either the grease trap or trash trap.

Pre-aeration provides benefits beyond oxidation. Some chemicals may be volatilized or directly oxidized by exposure to oxygen. Air aids in cooling and emulsifying fats, oil and grease so that they float to the surface. Generally, the wastewater will be homogenized so that the Multi-Flo does not experience sudden changes in wastewater character.

The microbes that perform the wastewater treatment occur naturally. When operation starts, bacteria takes from six-to-eight weeks to acclimate themselves to the wastewater and colonize in sufficient concentration that measurable treatment occurs. "Seeding" can be used to eliminate this start-up performance lag. Seeding is accomplished by obtaining about 50 gallons of mixed liquor from another Multi-Flo unit. The already-acclimated, concentrated colony should experience no delay in acclimating to the new unit so that a performance lag may be circumvented.

Cellular activity varies with the temperature. Microbes are less active in the winter, so seeding is essential for winter-time startup.

Table 8 should be used to determine the minimum hydraulic capacity of Multi-Flo systems to serve commercial facilities that do not have kitchen or laundry wastes. In some cases, pretreatment facilities may be required if average wastewater strength exceeds 300 mg/L CBOD₅ or if large volumes of wastewater are generated during peak periods. Whenever the daily wastewater flow is great enough to require more than one Multi-Flo unit, flow splitting should be used for even flow between or among units. Multi-Flo are not operated in series, nor should the flow be split between or among units of different capacities.

Please contact our local factory representative to determine if additional facilities may be required.

Average Daily Flow	Recommended Size of Pretreatment-Tank	Multi-Flo Unit(s)
0 – 500 gpd	300 gallon	FTB-0.5
501 – 600 gpd	300 gallon	FTB-0.6
601 – 750 gpd	500 gallon	FTB-0.75
751 – 1000 gpd	500 gallon	FTB-1.0
1001 – 1200 gpd	750 gallon	Two FTB-0.6
1201 – 1500 gpd	1000 gallon	FTB-1.5
1501 – 2000 gpd	1000 gallon	Two FTB-1.0
2001 – 2250 gpd	1000 gallon	Three FTB-0.75
2251 – 3000 gpd	1500 gallon	Two FTB-1.5
3001 – 4500 gpd	2000 gallon	Three FTB-1.5
4501 – 6000 gpd	2000 gallon	Four FTB-1.5

In designing a system for a commercial occupancy, the designer should consider the following:

- Maximum Month Average Daily Flow
- Minimum Month Average Daily Flow
- Peak Daily Flow
- Peak Hourly Flow
- Concentration and Mass of CBOD₅ for Flows
- Concentration and Mass of TSS for Flows

Operation and Maintenance Procedures for Seasonal or Intermittent Use Facilities

Frequently, Multi-Flo systems are installed at facilities that are used intermittently or seasonally. Because of the reduced or sporadic loading that these installations receive, the routine service and maintenance requirements are different from that normally expected of a year-round residence. The following recommendations are for the operation and maintenance of both residential and commercial systems that will not be operated on a full-time basis.

Seasonal Facilities are characterized by regular usage for several consecutive months, followed by several months during which no flow enters the unit. If the periods of non-use exceed three months, the Multi-Flo should be shut down and “winterized” by the following procedures:

- 1) Disconnect the unit at the breaker box and unplug alarm.
- 2) Completely pump out all sludge and liquids from the basin.
- 3) Flush and clean effluent filters, if installed, and Multi-Flo filter “socks.”
- 4) Fill unit with clean water.

- 5) Take the aerator out of the unit and clean it by lightly coating it with oil to prevent rusting. Store the aerator upright until the next season operation resumes.

Upon resuming normal use, install the aerator, plug in the alarm, re-connect the unit at the breaker box, and seed the unit. Winterizing and start-up should be performed by an authorized Multi-Flo distributor to insure proper operation of the system.

Intermittent use facilities are characterized by periodic occupancy followed by periods of vacancy. Typically, the vacancy will not last longer than three months. If the unit will be unused for less than three months, timed aeration may be better. Timed aeration consists of connecting the aerator to a timer that limits aeration operation at from two-to-four hours daily. Timed aeration will prevent anaerobic conditions and reduce the power consumption.

- 1) Weekend use: If the system will be used for short periods but on a regular basis (i.e., every weekend throughout the year), timed aeration may be provided during periods of non-use.
- 2) Vacation homes: If the system will be used for several weeks followed by several months of vacancy, the Multi-Flo may be shut off during vacancies. Pumping is generally unnecessary. If possible, the Multi-Flo should be allowed to run a few days after flow has stopped to oxidize any remaining organic material. As a part of start-up, the Multi-Flo distributor should check the unit to insure that the system is operational.

During periods of occupancy, the Multi-Flo unit must be operated in accordance with the manufacturer's recommendations and NSF certification.

During start-up, units may be prone to "sudsing," which is the production of foam from laundry detergents. Laundering should be limited during this period.

Where freezing is a danger, the Multi-Flo should be pumped during vacancies. Where uplift is a possibility, the uplift restraint must be provided.

Design Examples

Examples 1, 2, and 3: Residential Occupancies—Residential occupancies are generally designed based on the number of bedrooms, the daily flow assigned for each bedroom. Figure 12 shows typical layouts for single- and multiple-family dwellings. A trash trap is generally optional for single-family, owner-occupied dwellings. A trash trap is advisable for all rental property.

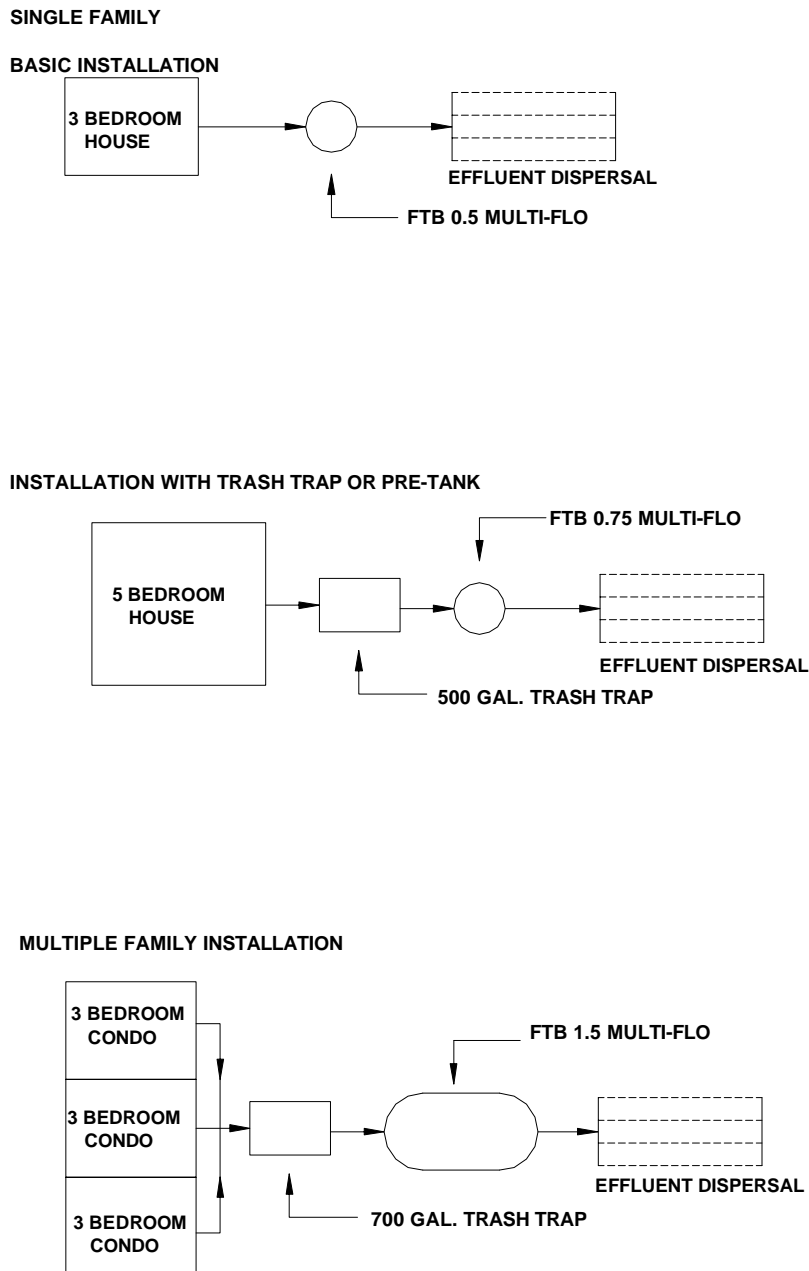

Figure 12—Examples 1, 2, & 3

Example 4: Commercial Occupancy, Office Buildings—Office buildings are designed based on the number of employers, frequenters, and based upon the presence of foodservice facilities. Figure 13 shows a layout of an office building that does not possess foodservice facilities. In designing a system for an office building, consideration must be made for the fact that the design flow may be generated within an 8-to-10 hour period. Thus, flow equalization may be essential to address surges into the Multi-Flo unit. Figure 13 illustrates two typical office building layouts.

Table 10—Example 4 Information	
Parameter	Value
Hydraulic Loading	20-25 Gal/Employee 20-25 Gal/Parking Space
Organic Loading	.04 Lb CBOD ₅ /Employee (240 mg/L CBOD ₅)
Grease Trap	Not Required
Trash Trap	500 Gallon
Pre-Aeration:	Not Required
Flow Equalization	Recommended

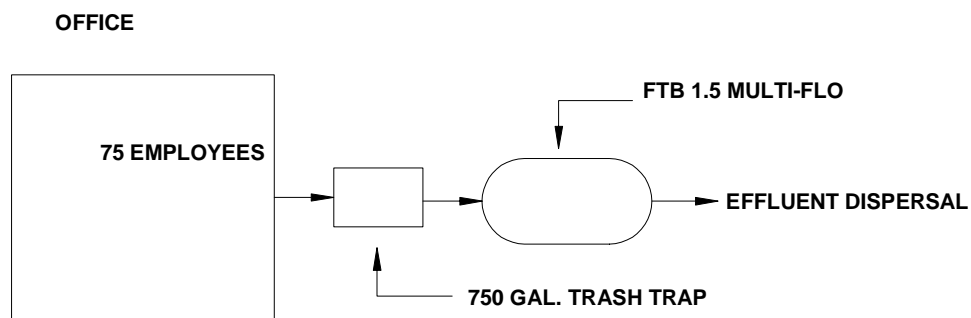
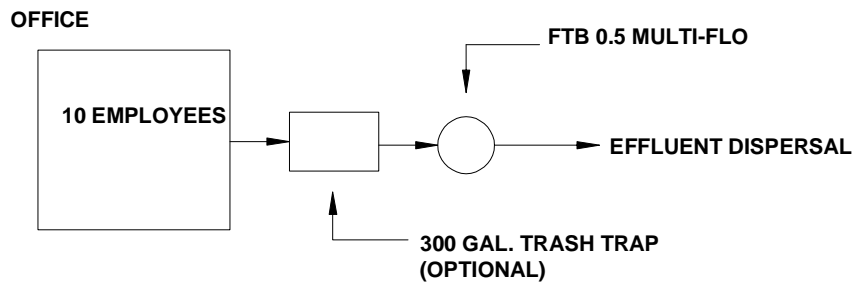

Figure 13—Example 4

Example 5: Commercial Occupancy, Retail Shopping Center Without Foodservice—Retail space wastewater flow is generally calculated based on the number of employees and number of frequenters. Often, the number of frequenters is estimated from the area of retail space.

Table 11—Example 5 Information	
Parameter	Value
Hydraulic Loading	(Retail Sales) 0.1 gal per sq. foot (Office Space) 20-25 gal per employee
Organic Loading	Retail Sales: .3 lb BOD per 1000 sq ft of floor space Office Space: .04 lb BOD per employee
Grease Trap	Not Required
Trash Trap	750 Gallon
Pre-Aeration:	Not Required
Flow Equalization	Recommended

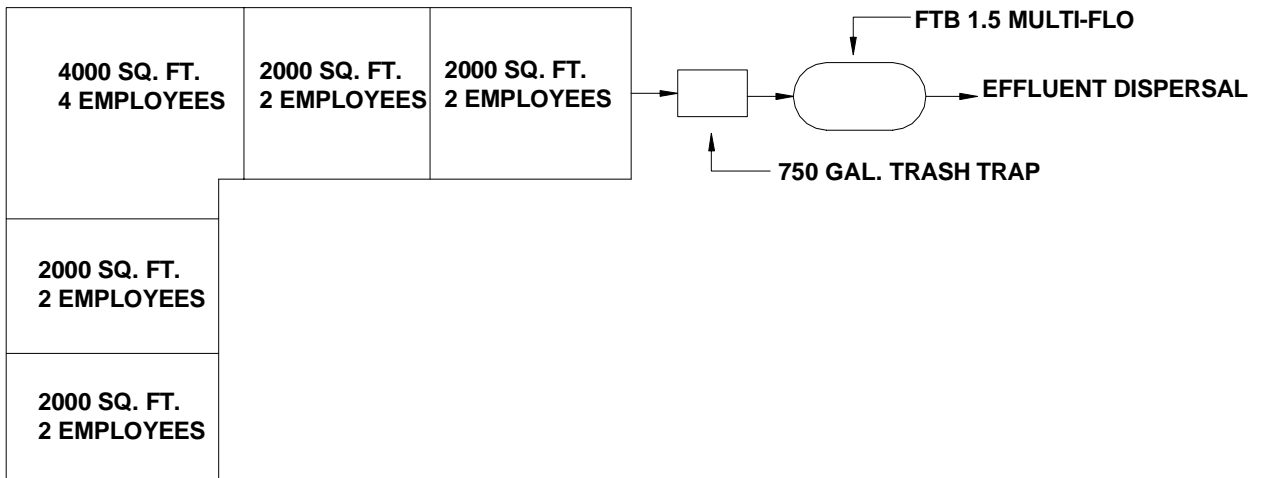

Figure 14—Example 5

Example 6: Commercial Occupancy, With Retail Shopping Plaza With Food Service/Laundry—It is important to provide adequate treatment (and pre-treatment) capacity for this type of facility. The initial design should indicate whether or not a food service or laundromat is proposed so that the Multi-Flo system can be properly designed. Failure to properly design the treatment system will probably result in a system failure when the food service or laundromat is added.

Table 12—Example 6 Information		
Parameter	Value	Total
Hydraulic Loading	20,000 sq. ft. @ 0.1 gal/sq.ft.	2000 gal.
	20 seat restaurant @50 gals/seat	1000 gal.
	6 machine laundromat @ 400 gal/machine	2400 gal.
		5400 gal/day
Organic Loading	BOD of 600-800 mg/L for new facility	
Example	20,000 sq.ft.@0.03 lb/BOD/1000 sq.ft.	6.0 lb BOD
	20 seats(restaurant) @0.35 lb BOD/seat	7.0 lb BOD
	washing machines @ 2.0 lb BOD/machine	12.0 lb BOD
		24.4 lb/day
Grease Trap	required	
Trash Trap	required: min. capacity of 2700 gal.	
Anticipated Service Requirements	routine inspection	1-2 months
	pumping	6-12 months
	filter cleaning	3-12 months

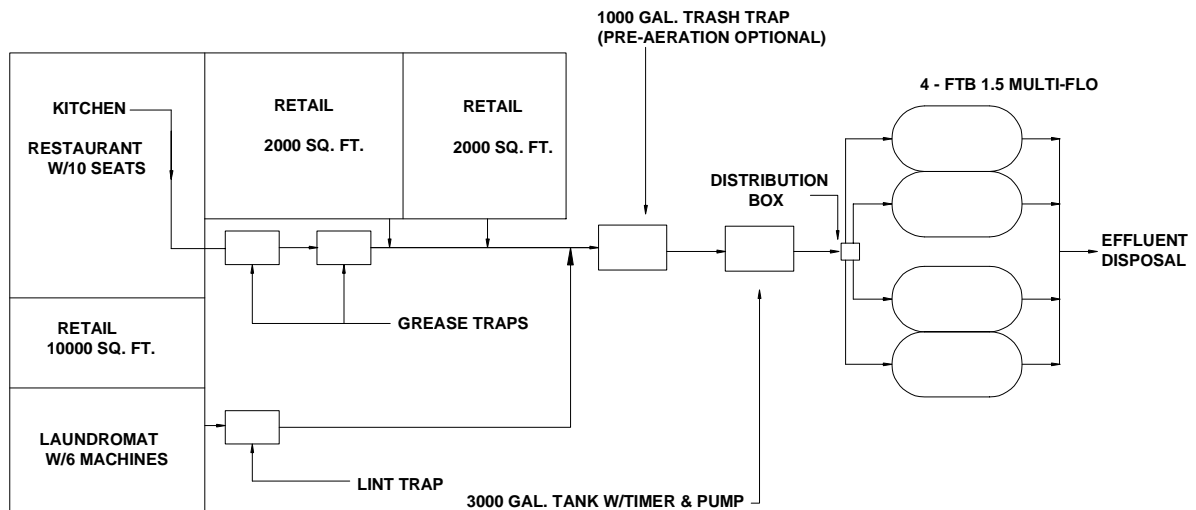

Figure 15—Example 6

Example 7: Commercial Occupancy—Mobile Home Park—Mobile home parks are usually characterized by relatively low (100 – 200 gpd) wastewater flows from each mobile home. For this reason, it is advisable, as well as cost effective, to group several mobile homes on one Multi-Flo system.

Table 13—Example 7 Information		
Parameter	Value	Total
Hydraulic Loading	1400 gal./day	
Organic Loading	0.40 lb BOD per space per day	
Pre-aeration	not required	
Flow equalization	not required unless there is a separate laundry building	
seeding for start-up	not required	
Anticipated Service Requirements	routine inspection	3-6 months
	pumping	1-2 years
	filter cleaning	1-2 years

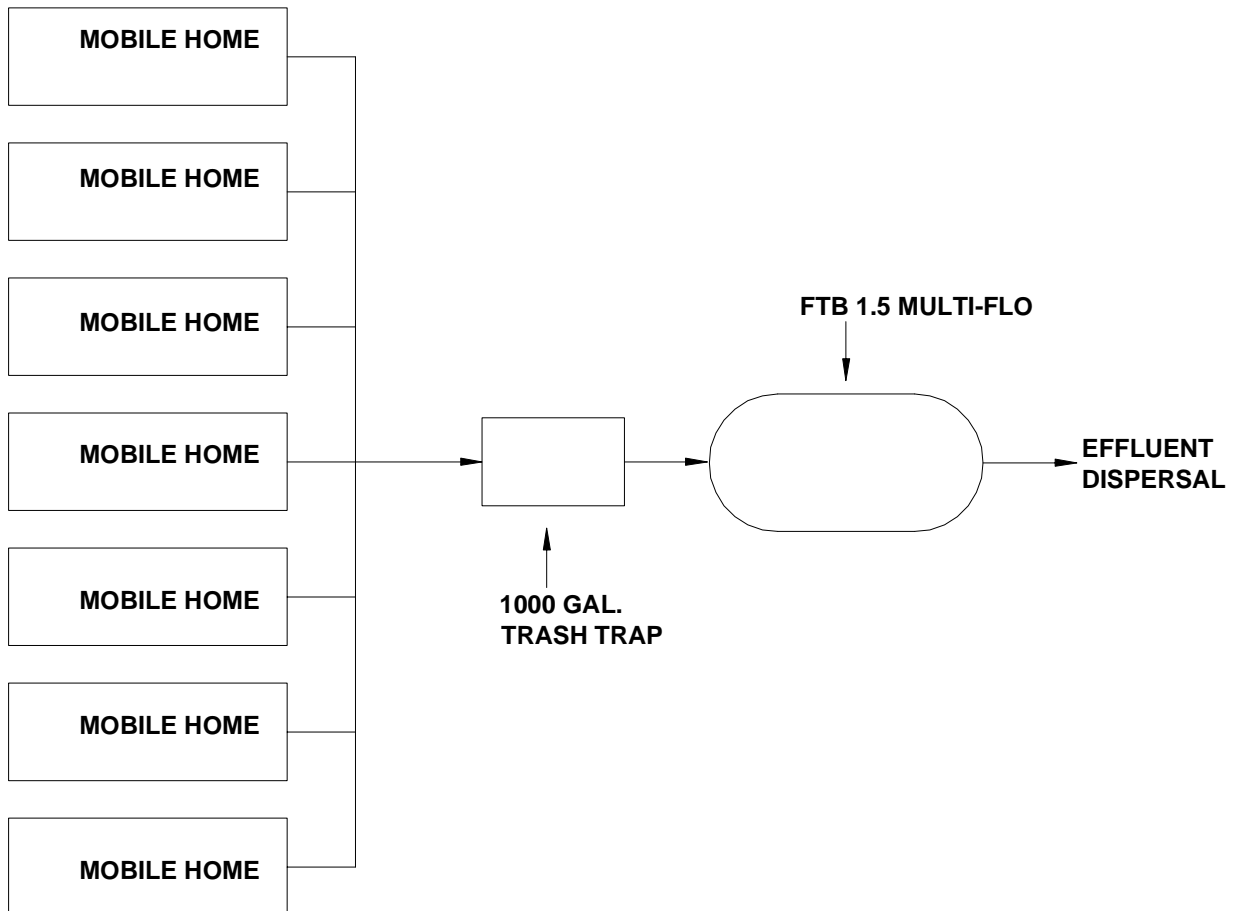

Figure 16—Example 7

Example 8: Commercial Occupancy—Institution—Institutional facilities present several problems that must be addressed in the total design. Depending upon the type of facility involved, consideration must be given to possible food service, laundry facilities, showers, as well as high water usage and heavy peak flow periods.

Table 14—Example 8 Information		
Parameter	Value	Total
Hydraulic Loading	hospital	200 gal/bed
	nursing home	100 gal/bed
	school	15 gal/student
	employee	20 gal/person
	kitchen	5 gal/person
	showers	5 gal/student
	laundry	400 gal/machine
Organic Loading	hospital	0.7 lb BOD/day per bed
	nursing home	0.3 lb BOD/day per bed
	school	0.03 lb BOD/day per student
	employee	0.04 lb BOD/day per employee
	kitchen	0.03 lb BOD/day per meal
	showers	0.01 lb BOD/day per student
	laundry	2.0 lb BOD/day per machine
grease trap	required	
trash trap	required	3,000 gal.
Pre-aeration	required if oxygen requirements exceed the capacity of the Multi-Flo unit	
Flow equalization	"	
seeding for start-up	"	
Anticipated service	routine inspection	monthly
requirements	pumping	6-12 months
	filter cleaning	6-12 months

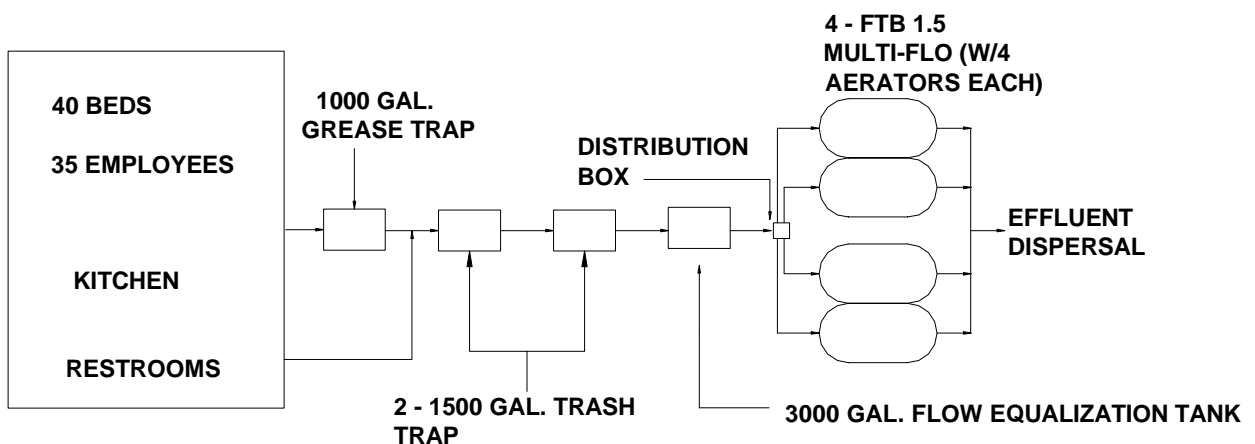

Figure 17—Example 8

MULTI-FLO

WASTEWATER TREATMENT SYSTEMS

MANUAL FOR OPERATION, MAINTENANCE AND TROUBLE-SHOOTING GUIDE

A Division of Consolidated Treatment Systems, Inc.
1501 Commerce Center Drive
Franklin, OH 45005
Tel: 937-746-2727
Fax: 937-746-1446
www.multi-flo.com

I. BASIC OPERATION AND MAINTENANCE REQUIREMENTS

The following is a description of the normal maintenance required to insure continuous satisfactory operation of the **MULTI-FLO** systems:

START UP:

Allow 6-to-8 weeks for sufficient bacteria to provide proper treatment in the **MULTI-FLO**. During this period, there may be sudsing from laundry wastes. *Sudsing can be reduced by limiting the volume of laundry washed daily and by using a low-sudsing detergent.* In situations where excessive laundry water is expected, “seed” the **MULTI-FLO** with “mixed liquor” from another unit. To prevent short-term hydraulic overloads, spread out laundry washing.

PUMPING EXCESS SOLIDS:

Periodic pumping is necessary to remove excess bacteria and other solids. For a typical single-family dwelling, the **MULTI-FLO** will require pumping at 2-to-4 year intervals. **MULTI-FLO** representatives can advise customers when their **MULTI-FLO** should be pumped.

FILTER CLEANING:

Filters should be cleaned whenever a **MULTI-FLO** is pumped. Filters may need to be laundered if the aerator is shut off for extended periods or they are plugged by grease, soap, residue or solids.

AERATOR REPLACEMENT:

The average life expectancy of the aerator is 3-4 years. New and replacement have a two-year warranty.

ALARM:

MULTI-FLO alarm systems indicate both aerator failure and filter plugging. Although the homeowner will not normally experience immediate filter plugging, the **MULTI-FLO** service representative should be notified as soon as the alarm is activated.

SERVICE CONTRACT:

MULTI-FLO units require periodic maintenance. With the purchase of each **MULTI-FLO**, every owner receives a two-year service contract, which provides a warranty on all parts service, including a minimum of two inspections of the unit each year. After the initial two years of operation, owners are urged to maintain their service contracts to insure regular inspection and service of the **MULTI-FLO** system. **NOTE: The warranty does not include misuse or abuse of the system.**

REPLACEMENT PARTS/SERVICE:

Contact the factory for the name of the closest sales/service representative.

SUMMARY OF MAINTENANCE REQUIREMENTS (Residential)

Start up period 6-to-8 weeks after sewage first enters unit

Pumping frequency every 2-to-4 years

Filter cleaning..... every 2-to-4 years

Aerator replacement 3-to-4 years

Routine inspection frequency..... every 6 months (minimum)

NOTE: Due to differences in wastewater strength, increased user abuse, and hydraulic surges, additional treatment facilities and/or increased maintenance may be required. Please check with your **MULTI-FLO** representative.

II. EQUIPMENT AND MATERIAL ESSENTIAL FOR SERVICING MULTI-FLO UNITS

100' garden hose with spray nozzle

100' extension cord

1/3 hp submersible pump (little giant) with outlet made of flex pipe.

Small utility pump with 1/2 - 5/8" garden hose (6') on inlet and outlet (Teal model IP 579E, Simer Minivac Model M40 or equal.)

Pliers - standard with insulated handles

Pliers - channellock

Caulking gun

Caulking, silicone

Hammer

Electrical tape

Wire nuts

Knife

Screwdriver

Replacement parts:

- aerator

- filter bag expanders

- filter bags

- stainless steel spring clips

- pressure switches (for old style units)

- alarm

- latch assembly

Wiping rags

Gasket material

Adhesive for gasket

Volt ohm amp meter

Sample collection jars (1 quart capacity)

III. SERVICING PROCEDURES

- Note: During all service procedures, be sure to observe good hygiene practices, including wearing gloves and proper hand washing.
- Step 1 Layout garden hose, wiping cloths, tools, electrical tape, utility pumps, and extension cord.
- Step 2 Turn off electrical power to **MULTI-FLO**.
- Step 3 Remove lid to **MULTI-FLO**. Check surge bowl for signs of high water or foaming. Check the area around the **MULTI-FLO** for signs of previous overflow.
- Step 4 Wash the inside of the lid and surge bowl of **MULTI-FLO**.
- Step 5 Remove the surge bowl and check the gasket on both the bottom and top. If it is loose, re-glue it; if it is damaged, replace it with *new gasket material*.
- Step 6 Check the filters for possible plugging by running water into the center chamber and check for a quick, noticeable rise in the water level inside of the tower. If filters are plugged, follow procedures outlined under "Filter Cleaning."
- Step 7 Collect a sample of the mixed liquor for a settleable solids test.
- Step 8 Using the utility pump, vacuum the top of the weir to remove accumulated solids. Follow procedures outlined in this manual under "Cleaning the Hanger Plate and Weir: Procedure." Check for sludge build-up in the bottom of the filter bags. If the solid accumulation on top of the weir is excessive (greater than 1/2" thick) or appears to noticeably be more concentrated in one area, check for a torn filter(s), improper placement of clips, thin filter material, or a gap between the hanger plate and the ring on the top of the filter. Make appropriate corrections.
- Step 9 Remove aerator and check for accumulation of foreign material wrapped around impeller.
- Step 10 Replace aerator and check the intake tube to insure that it does not have any blockage. On newer units, check to ensure the clear plastic tube is not twisted or kinked. Kinks in the hose will cut off aeration to the treatment tank and allow septic conditions to develop. The plastic line on pressure switch unit must not kink.
- Step 11 Reinstall the surge bowl. **Make sure that the flat surface of the surge bowl is placed next to the electrical box or that the black marking stripes align properly.**
- Step 12 Close lid to **MULTI-FLO**. Make sure the lid is properly secured with a tamper-proof bolt, padlock or other approved locking device.
- Step 13 Turn on the electrical power to the **MULTI-FLO**.
- Step 14 Check out alarm system.
- Step 15 After appropriate settling time (possibly 24 hours) check settleable solids reading to determine if the **MULTI-FLO** should be pumped before the next routine service call. Advise homeowner accordingly.
- Step 16 **Be sure to leave the owner notice of the inspection/service call, inspection results, service provided, and recommendations.**

IV. PUMPING

Bacteria and other microorganisms present in the wastewater use soluble organic material as a food source, converting it into more microorganisms (biomass), water, and carbon dioxide. As the colony matures, the numbers of microorganisms increase until they exceed the supply of organic material to maintain them. Due to the resulting starvation, organisms will begin to die and then be metabolized as new organisms are formed. Metabolized organisms reduce the overall solids (or “sludge”) volume.

There will be a gradual increase in solids due to the accumulation of inert remains of dead organisms and non-degradable material in the wastewater. As the solids increase, the mixed liquor becomes thicker, reducing the scouring effect on the filters. Periodically, the solids must be pumped from the **MULTI-FLO** to prevent filter plugging and maintain adequate aeration within the system.

PUMPING FREQUENCY:

The rate of solids accumulation—and resultant pumping—is dependent upon the quantity and strength of wastewater entering the plant, i.e.; the greater the waste load, the more frequently the **MULTI-FLO** should be pumped. Normally, residential systems should be pumped every 2-to-4 years. Units serving commercial occupancies may need to be pumped every 1-2 years, depending on the waste load.

DETERMINING PUMPING FREQUENCY:

Trained service personnel can help owners establish a pumping frequency by performing a 24-hour settleable solids test of the mixed liquor during semi-annual service:

Procedure

1. Mark a quart jar into 10 equal portions
2. While aerator is running, fill the jar with mixed liquor suspended solids by lowering the jar into the center aeration chamber.
3. Measure the percent of the original volume occupied by the sludge after it has settled for 24 hours.

The optimum level of settleable solids (24 hours) is normally between five and 50 percent. Whenever the percent of settled sludge exceeds 50%, the unit should be pumped.

PROCEDURE FOR PUMPING THE MULTI-FLO:

1. Shut off the **MULTI-FLO** and allow solids to settle for 30-60 minutes.
2. Remove access cover and the surge bowl.
3. Lower the hose into the center aeration chamber. *Care should be taken to avoid knocking or damaging the aerator, air intake tubing or power cord. Be careful with the older model FTB 0.75 because the aerator sits on a platform.*
4. Pump solids from the bottom. If the filters are not to be removed, be sure to hose down the filters and the bottom of the hanger plate.
5. Pump down the tank, until the liquid level is at the top of the aerator. This will leave sufficient seed material to allow start-up conditions to develop.

6. *In areas with a high water table, immediately refill the **MULTI-FLO** with clear water to prevent shifting or flotation.*

V. FILTER CLEANING

Under normal operating conditions, the filters in the **MULTI-FLO** do not require manual cleaning or backwashing. The extent of the bacterial buildup on filter surfaces is limited by the constant scouring from the aeration and sloughing of the solids.

The biomat that develops on the surface of the filter enhances filtration. Therefore, *cleaning of the filters is not recommended unless actual plugging is occurring.* The following conditions may cause plugging of the filters to occur:

1. Excess buildup of solids in the **MULTI-FLO** (see Pumping Procedures).
2. Extended septic conditions (see Aerator Replacement). Normally, the filters will not plug unless septic conditions exist for a period more than 7-to-10 days.
3. Excessive grease entering the **MULTI-FLO**. This may become a problem at a food service facility or in a home with a garbage disposal.
4. Hydraulic overload. (See Troubleshooting Guide for remedies.)
5. Organic overload. (See Troubleshooting Guide.)

CLEANING PROCEDURE (Standard Procedure):

1. Remove spring ring retainer from filter.
2. Without removing the filters, grasp the filter by the ring at the top and move it up and down in the weir to scrape off the accumulated solids and biomat.
3. Check the interior of the filter. If there is an accumulation of sludge in the bottom, remove the filter and pour the sludge into the aeration chamber.
4. Replace the filter in weir and push back in place. Replace the spring ring retainer.
5. If the water fills up the filter as fast as it is being pushed down through the weir, no further cleaning is required. Follow the same procedure with the remaining filters. **NOTE: This procedure is only recommended when done during routine pumping. If the above procedure does not adequately cleanse the filters, or if the plugging resulted from other causes perform the following procedures:**
 - a. Replace the existing filters with a clean set.
 - b. Launder the old filters on gentle cycle and allow them to air dry (do not use a heated dryer as this will damage filters). Add bleach with the detergent (or during the rinse cycle) to enhance the cleaning of the filters and provide personal health protection.

Do not attempt to clean the filters by washing them with a garden hose or pressure washer. This can damage the filters or leave a residue within the fabric which will cause the filters to plug prematurely.

Hydraulic or organic overloads should be considered if filters plug frequently (i.e., less than 12 month intervals), or shortly after the unit goes into operation. Contact the **MULTI-FLO** distributor or factory representative for assistance.

VI. CLEANING THE HANGER FILTER PLATE AND WEIR

Often, "pin floc" (less than 0.03 inches in diameter) forms as a result of over-oxidation of the sludge. Pin floc is observed in units with low hydraulic loads and long retention times, which allow digestion of the bacterial cells to occur. These fine, mostly inert, solids may pass through the filter fabric, especially if an inadequate biomat has formed on the filter surface. Pin floc may occur in new units though hydraulic surges (laundry, showers, etc.) may also force some of the small particles through the filters.

Pin floc usually settles to the bottom of the filters. However, some of the particles may be carried upward through the filters and settle on the upper surface of the hanger filter plate. It will be necessary periodically to remove the settled solids from both the hanger plate and inside of the filters to prevent solids from being carried over the weir.

PROCEDURE:

1. Pump the settled solids off the top of the hanger plate using a 1/2 to 5/8 inch garden hose for an intake and discharge. Place the discharge end into the center chamber.
2. If there is a significant amount of settled sludge in the bottom of the filters, pump the sludge out using a 4 foot section of 3/4 inch PVC pipe attached to the end of the intake hose. If there is no access to a pump, remove the filter and pour the sludge into the center aeration chamber. If surface discharge of the effluent is used it is good policy to plug the 4 inch discharge line until cleaning is completed.

CLEANING FREQUENCY:

Under ordinary conditions, the top of the hanger and weir should be cleaned during each routine inspection (every 6 months). Sludge should be removed from the interior of the filters whenever it exceeds 6 inches in depth or if clumps of floc float at the top of the filter (approximately once every 12 months).

It is not advisable to remove or clean the filters more than is necessary. Unnecessary cleaning will wear or damage filters and expanders.

VII. AERATOR REPLACEMENT

PROCEDURE:

1. Turn off the electricity before working on aerator.
2. Remove the three wire nuts and disconnect the aerator electrical cord from the main power cable.
3. Loosen the pressure fitting in the center tower and gently pull the power cord through so that the aerator is free.
4. Grasp the air intake tube and raise the aerator until the upper union (located in the middle of the air intake tube) is visible.
5. Disconnect the sensor (upper) portion of the intake and lay it back on the hanger plate. The aerator is now free and can be moved from the **MULTI-FLO**.
6. Change aerators and replace in the **MULTI-FLO** by following the above procedure in reverse.

VIII. ALARM REPLACEMENT

PROCEDURE:

1. Turn off the electricity before working on the alarm.
2. Unplug the alarm or disconnect the power cord.
3. Unscrew the face plate of the alarm.
4. Remove the two wire nuts and disconnect the green and white sensor wires.
5. Remove the alarm box from the wall or mounting bracket and replace with a new alarm.
6. Reconnect the sensor wires (white to white; black to black).
7. Replace the face plate; plug in the alarm and restore power.
8. Check alarm by pressing test button.

IX. SAMPLE COLLECTION

MULTI~FLO units produce an effluent exceeding the performance requirements of NSF Standard 40 (Class I) for aerobic treatment plants: 30 day average of <25 mg/l CBOD and <30 mg/l TSS. Local health agencies may require periodic sampling to confirm this performance. If this is necessary, the following procedure should be followed.

To collect samples from the **MULTI~FLO**, care must be taken to get reliable and uncontaminated samples as **effluent is discharged from the unit**.

1. Provide a suitable port on the outlet of the **MULTI~FLO** (see Fig. 1). The port should be at least 6" in diameter, with a minimum depth of 8" below the effluent line.
2. Using a clean cloth, wipe the interior of the effluent line, where it enters the sampling port, to remove any debris that may have accumulated.
3. Drain water into the cleanout before the **MULTI~FLO**, to generate a flow through the unit. Allow the flow to continue for approximately one (1) minute to flush the line.
4. Shut off the water and dip the water out of the sampling port. Discard this water.
5. Turn on the water and collect a sample as effluent flows into the sampling port. Do not collect water that has accumulated in the sampling port. Take care to avoid catching dirt or other debris while collecting the sample.

Figure 1



**MULTI-FLO
TROUBLE-SHOOTING CHECKLIST**

<i>PROBLEM/CONDITION OBSERVED</i>	<i>POSSIBLE CAUSE</i>	<i>CORRECTIVE ACTION</i>
I. AERATOR		
A. Aerator will not run or continually kicks the circuit breaker.	1. Circuit breaker is inadequate for use.	1. Check circuit breaker. Should be at least 8 AMP, but should not exceed 15 AMP per aerator. Check for other appliances/pump connected to breaker.
	2. Impeller is rubbing on motor bracket.	2. Check gap between the impeller bracket by turning the impeller. Loosen set screw on cross and slide tight against motor housing. Replace impeller. Remove spacers until rubbing occurs, then add one or more until rubbing stops.
	3. Foreign material is caught on impeller.	3. Check aerator and move material.
	4. Worn motor is drawing excessive amperage or locking up completely.	4. Remove aerator from tank and check for proper operation by connecting to separate electrical receptacle. Check amperage to insure it does not exceed 2.4 Amps. If motor is faulty replace or send to factory (Consolidated Treatment) for repair.
	5. Power cord is cut or damaged.	5. Inspect cord and test for continuity. Replace if necessary.
	6. Wiring used for installation may be inadequate for loading and distance. Wiring may also be damaged.	6. Have wiring checked by licensed electrician and replace if necessary.
B. Motor hums but the impeller will not turn	1. Foreign material is caught on impeller.	1. Remove material.
	2. Impeller is rubbing on motor.	2. Refer to section I "Aerator".
C. Aerator runs but no air in intake pipe.	1. Foreign material in aerator.	1. Remove pipe, nipple and tee from aerator and flush with water.

**MULTI-FLO
TROUBLE-SHOOTING CHECKLIST**

<i>PROBLEM/CONDITION OBSERVED</i>	<i>POSSIBLE CAUSE</i>	<i>CORRECTIVE ACTION</i>
	2. Aerator has a loose impeller or key way is sheared from impeller.	2. Tighten bolt or replace impeller.
	3. Air intake pipe or plastic tubing is plugged	3. Flush with a garden hose and pressure nozzle.
	4. Plastic intake pipe tube is kinked	4. Re-align to remove kink. Plastic tubing may need to be replaced if the kink is permanent.
	5. Debris or scale build-up under impeller.	5. Remove impeller and scrape off material.

**MULTI-FLO
TROUBLE-SHOOTING CHECKLIST**

<i>PROBLEM/CONDITION OBSERVED</i>	<i>POSSIBLE CAUSE</i>	<i>CORRECTIVE ACTION</i>
II. ALARM		
A. Light does not come on when pressing the test button.	1. Alarm is not properly energized or the power is off.	1. Check alarm to insure it is plugged into a 115 VAC outlet and that the breaker is on.
	2. Alarm has a built in time delay.	2. Hold the test button for at least 15 seconds.
	3. Alarm is faulty.	3. Turn off aerator to check alarm. If alarm is not activated, replace with a new alarm or return to factory for repair.
B. Customer complains alarm is going off but at time of service the alarm is reset and the MULTI-FLO appears to be running normally.	1. A power outage.	1. Check to see if power outage has occurred. Alarm will come on after any power outage when the power is restored. This will occur for a few seconds only and will reset automatically. Push reset button on visual, and audio visual alarms.
	2. The filters are partially plugged causing a temporary surging of the water into the surge bowl during periods of heavy water usage such as laundry.	2. Refer to section V "Filter Cleaning".
	3. Sensor foam cap is missing.	3. Replace foam cap if missing.
	4. Moisture has collected under red sensor foam cap.	4. Remove and clean foam cap and top of metal sensor. Replace cap, leaving at least ¼" space between cap and sensor bolt.
	5. A partial blockage in the discharge line restricts flow out of the plant.	5. Check by running water from hose into outlet pipe and observe for back-up. If blockage exists rod out line or repair as required.
	6. The aerator motor is running intermittently due to the thermal overload when motor over heats.	6. Replace aerator.

**MULTI-FLO
TROUBLE-SHOOTING CHECKLIST**

<i>PROBLEM/CONDITION OBSERVED</i>	<i>POSSIBLE CAUSE</i>	<i>CORRECTIVE ACTION</i>
	7. High ground water in area causes back-up due to saturation of drainfield. Problem occurs during rainy periods.	7. Repair/Replace drainfield according to directions from health department.
C. Alarm is not activated when aerator is turned off.	1. Alarm box is not energized.	1. Check by pushing test button for 15 seconds. If light and/or buzzer are not activated, check to make sure alarm is plugged in and that the breaker is on.
	2. Sensor wires are not properly connected.	2. Check connection of the two wires in the alarm box to the cable from pressure/float switch (old style) or aerator/high water sensors (new style).
	3. Aerator sensors are corroded or dirty.	3. Flush airline and clean sensors located on the inside of the airline.
	4. (Old style) 3/8" tubing to pressure switch clogged or kinked so that proper pressure is not occurring at pressure switch.	4. Clean or replace tubing.
	5. (Old style) Leakage between the pressure switch and aerator tee which causes pressure loss.	5. Tighten all fittings and connections.
	6. (Old style) Faulty pressure switch.	6. Replace pressure switch.
	7. (Old style) Pressure switch connections are loose.	7. Check the pressure switch cable, restrip and connect the wires properly. Clean terminal and all connections.
D. Alarm does not go off due to high water in surge bowl.	1. Alarm box is not energized.	1. Check by pushing test button for 6-7 seconds. Check to make sure alarm is plugged in and that the breaker is on.
	2. Holes in red foam cap are plugged.	2. Clean cap or replace. Make sure that holes are at least 13/64" in diameter.

**MULTI-FLO
TROUBLE-SHOOTING CHECKLIST**

<i>PROBLEM/CONDITION OBSERVED</i>	<i>POSSIBLE CAUSE</i>	<i>CORRECTIVE ACTION</i>
	3. (Old style) Float switch is not connected to the alarm cable.	3. Strip and clean the ends of the alarm cable and float cable. Reconnect with wire nuts.
E. Alarm stays on all the time even when the aerator is running and filters are OK.	1. Sensor wires in the alarm box are touching.	1. Check to make sure the wires are properly connected: white to white and black to black.
	2. Black and white wires are wired incorrectly.	2. Reverse connection of white and black wires in the alarm box.
	3. Sensor wires are damaged in air intake assembly.	3. Replace air intake assembly.
	4. Aerator sensors are shorting out.	4. Remove top air intake assembly and check sensor. If they are touching, hold one sensor with needle nose pliers and push up second sensor with a screw driver so that they no longer touch.
	5. The alarm is faulty.	5. Replace alarm or return to factory for repair.
	6. Debris or water has collected under red sensor cap.	6. Remove cap and clean cap and sensor. Replace cap making sure there is about 1/4" gap between the sensor and cap.
	7. (Old style) Float switch is faulty.	7. Replace float switch.
	8. (Old style) Pressure switch is faulty.	8. Replace pressure switch.
	9. (Old style) Moisture has collected in pressure switch.	9. Replace pressure switch and allow old switch to dry.
	10. (Old style) 3/8" tubing to pressure switch is clogged.	10. Clean tubing.

**MULTI-FLO
TROUBLE-SHOOTING CHECKLIST**

<i>PROBLEM/CONDITION OBSERVED</i>	<i>POSSIBLE CAUSE</i>	<i>CORRECTIVE ACTION</i>
III. FILTERS		
A. Unit is overflowing or backing up into house.	1. Filters are completely or partially plugged.	1. Run water into the surge bowl. If water does not pass through filters causing a noticeable and rapid rise in the water level, follow the procedures for cleaning filters.
	2. Filters are plugged due to excessive solids concentration.	2. Perform 60 minute settleable solids test. If results are >50% and unit has been in use for 2+ years, follow the procedures for pumping.
	3. Filters are plugged due to septic conditions. This is indicated by black or grey color of aeration tank and filters: Aerator may be inoperative or running very slowly. If necessary, check with air flow meter to insure a minimum of 1.5 ft ³ /m.	3. Check breaker or power source to insure power is provided to aerator. Remove aerator and connect directly to power source. If aerator is inoperative, replace or return to factory for repair.
	4. Filters are plugged due to grease or soap residue.	4. Check for improper use of garbage disposal. If noted, discontinue use or provide a trash trap. If grease continues to accumulate in MULTI-FLO, check sewer line from building for grease build-up
	5. Filters are plugged due to excessively high BOD (organic loading). This would be indicated if the influent (raw) BOD exceeds 350 mg/l.	5. Contact your MULTI-FLO factory representative for assistance.
	6. Filters are plugged due to excessive hydraulic flows (daily flows average more than 70% of plant design); or, peak flows/hydraulic surges (any hourly flow rate greater than 10% of plant design).	6. Contact your MULTI-FLO factory representative for assistance.

**MULTI-FLO
TROUBLE-SHOOTING CHECKLIST**

<i>PROBLEM/CONDITION OBSERVED</i>	<i>POSSIBLE CAUSE</i>	<i>CORRECTIVE ACTION</i>
	7. Filters are plugged due to extraneous water entering the system (i.e., leaking fixtures, floor drains, etc.)	7. Check for sources of non-sewage flows to system. If they exist, they need to be disconnected or repaired.
	8. Filters are plugged due to the growth of "filamentous" organisms in the treatment plant. These organisms produce an extra-cellular "slime" which can seal off the filter surface. The causes of these organisms can be due to low pH (<6.0); low dissolved oxygen; septic influent containing high sulfide or iron levels; nutrient deficiency; or recovery from a toxic upset. Waste waters containing high levels of grease or carbohydrates may also stimulate the growth of these organisms. Occasionally, heavy continued use of medications may be a factor.	8. Contact your MULTI-FLO factory representative for assistance.
	9. Filters are plugged due to the introduction of toxic materials into the treatment plant, preventing the growth of normal bacteria. Refer to item VI, C (odors).	9. Contact your MULTI-FLO factory representative for assistance. Possible causes include water softener backwash, continual use of medications, drain cleaners, bleach, etc.
B. Accumulation of solids on hanger plate above filters (solids settle out but accumulate more heavily on certain sections of the hanger	1. Torn or damaged filter (large air bubbles will be noted coming up the inside of the filter plate).	1. Replace filter.
	2. Filters are not properly fitted to hanger plate (small bubbles will be coming around the edge of the filter ring).	2. Remove clips; re-set filter, making sure the cloth is not caught between the ring and the hanger plate; replace clips. Make sure the clips are set at right angles to each other.
	3. Solids have settled in bottom of filters and are beginning to "denitrify" causing solids to float to the top of the filter.	3. Pump settled sludge out of filters.

**MULTI-FLO
TROUBLE-SHOOTING CHECKLIST**

<i>PROBLEM/CONDITION OBSERVED</i>	<i>POSSIBLE CAUSE</i>	<i>CORRECTIVE ACTION</i>
C. Accumulation of scum layer which floats on the surface of the water (i.e., effluent) above the filters.	1. Damaged gasket on the bottom of the surge bowl.	1. Replace gasket.
	2. Residue of brown foam which has overflowed from under the lid and adhered to the bottom of the surge bowl.	2. Refer to Section V" Foaming".
	3. Poor seal between gasket on bottom of surge bowl and access tower, allowing seepage to occur under the surge bowl.	3. Install a tower ring adapter to provide a tighter seal.
D. On new installations, a grayish material develops on the hanger plate; effluent is clear, free of solids.	1. A fungus develops due to the soluble nutrients from laundry waste. Plant has not matured.	1. Using utility pump, clean off hanger plate. Generally, the growth will not re-appear. If so, contact the factory representative for assistance.

**MULTI-FLO
TROUBLE-SHOOTING CHECKLIST**

<i>PROBLEM/CONDITION OBSERVED</i>	<i>POSSIBLE CAUSE</i>	<i>CORRECTIVE ACTION</i>
IV. SUDSING		
A. During start-up, white frothy suds build up in the surge bowl. In extreme cases the suds may seep out under the lid.	<ol style="list-style-type: none">1. Insufficient bacterial development in plant. Although typically a start-up condition (6-8 weeks), intermittent or light usage can create similar conditions.2. Excessive use of laundry detergent. This can be an on-going problem with lightly loaded or intermittently used installations.	<ol style="list-style-type: none">1. Space out laundry. A defoamant block (purchased from the manufacturer) can also be installed to reduce foaming tendencies. Refer to recommendations on laundry.2. Reduce the amount of laundry detergent used per load. This will also provide a cost savings to the homeowner. Again, the use of a defoamant block can be beneficial.

**MULTI-FLO
TROUBLE-SHOOTING CHECKLIST**

<i>PROBLEM/CONDITION OBSERVED</i>	<i>POSSIBLE CAUSE</i>	<i>CORRECTIVE ACTION</i>
V. FOAMING		
<p>A. A thick, brown, leathery foam builds up in the surge bowl. In extreme cases, particularly during laundry, the foam will overflow under the lid, leaving a sludge-like residue on the ground.</p>	<p>1. Organic foam is due to a heavy accumulation of solids in the plant. This condition may occur after the system has been in use for 3-4 years.</p>	<p>1. Perform 24 hour settleable solids test. If test results are >50%, follow the procedures for pumping the MULTI-FLO.</p>
	<p>2. Sudden change in organic loading to the plant. This may occur during holidays, change in usage (commercial) or during periodic cleaning activities (commercial). A seasonal temperature change may cause a temporary foaming condition.</p>	<p>2. If the "shock load" is a one-time occurrence, or happens infrequently, there is little to be done. It may be helpful to shut off the plant (not to exceed 48 hours).</p>
	<p>3. Growth of filamentous organisms. Refer to sections III A8: Filter plugging</p>	<p>3. This typically occurs on commercial facilities or food services. Contact your factory representative for assistance.</p>

**MULTI-FLO
TROUBLE-SHOOTING CHECKLIST**

<i>PROBLEM/CONDITION OBSERVED</i>	<i>POSSIBLE CAUSE</i>	<i>CORRECTIVE ACTION</i>
VI. ODORS		
A. Plant has a strong septic odor and the aerator is not running.	1. Aerator is inoperative due to loss of power or mechanical problems.	1. Refer to Trouble-Shooting Guide: Aerator.
B. Aerator is running and the mixed liquor has a normal brown color. Odor may be intermittent.	1. Installation has a pre-tank which generates odors during heavy water usage such as laundry.	1. Provide a Sch. 40 4" PVC elbow on the inlet to the MULTI-FLO. Add a 12" extension that discharges under the water.
	2. Installation has a dosing pump preceding the MULTI-FLO. Too much septic waste is being dosed one time.	2. Check the dosing rate. If required, re-set the floats (or timer) to pump no more than 10-20 gallons per dose. Also, install a 4" elbow as described above.
C. Aerator is running but mixed liquor (aeration chamber) has a grey, dishwater appearance. Filters usually plug within a few months. The top of the hanger plate may have a grey septic appearance with black, slimy growth (generally, this condition is observed on commercial facilities or food establishments).	1. Hydraulic overload, including a peak. Short term "shock" loading.	1. If the daily average flow >70% of the plant's capacity, flow equalization may be required. Contact your factory representative.
	2. Excessive grey water, resulting in hydraulic overload in addition to nutrient imbalance.	2. Provide a separate grey water system or install water-saving devices. Contact your factory representative.
	3. Use of over-sized pre-treatment tank.	3. If pre-tank capacity is more than 200% of MULTI-FLO capacity, replace the pre-tank with a smaller size or eliminate entirely if daily flows are <25% of MULTI-FLO capacity.
	4. Presence of inhibitory or toxic materials in waste water. This can also include medications and antibiotics.	4. Contact your factory representative for recommendations if you suspect this is a problem.

**MULTI-FLO
TROUBLE-SHOOTING CHECKLIST**

<i>PROBLEM/CONDITION OBSERVED</i>	<i>POSSIBLE CAUSE</i>	<i>CORRECTIVE ACTION</i>
	5. Water leaks, sump pump discharges or downspouts connected to sewer allow the discharge of excessive amounts of clear water.	5. Check temperature of aeration, if the temperature is less than 60 ⁰ F, check for possible leaks or storm water connections. If found, disconnect.
D. Aerator runs, but plant has a dark brown or black appearance and a strong septic odor.	1. Organic overload. 2. Aerator is not providing sufficient air flow (oxygen). Check with air flow meter to insure a minimum of 15cfm.	1. Check influent BOD. If >350 mg/l, additional treatment may be required. Contact your factory representative. Refer to Section I C1-5.
E. MULTI-FLO is running normally, with good effluent quality, but odor is observed to be coming from auxiliary components such as a chlorine contact tank, or effluent pump tank. Effluent may be slightly turbid.	1. Accumulation of solids or debris in pump tank or chlorine contact tank. This can occur during routine servicing procedures.	1. Pump or flush contact tank or pump chamber to insure all solids residue is removed. As an extra precaution, pour ½ to 1 gallon of household bleach into the pump tank or contact chamber.

**MULTI-FLO WASTE TREATMENT SYSTEM
OPERATIONAL CONTROL CHART**

OPERATION CONDITION	COLOR: AERATION TANK	ODOR	PERCENT SETTLABLE SOLIDS	EFFLUENT QUALITY	FILTER CONDITION	POSSIBLE PROBLEM	CORRECTIVE ACTION
Plant start-up 0-6 weeks	Clear to light brown; White suds	None	< 5%	Clear	No signs of plugging	None: Normal start-up condition	No action required Re-check in 6 months
Plant start-up 0-6 weeks	Clear to light brown; Heavy white suds periodically overflow under lid, mostly during laundry.	None	< 5%	Clear	No signs of plugging; possible grey growth on filter hanger plate	Light loading to plant; insufficient food for organisms. Sudsing due to hydraulic overload during laundry	Reduce frequency of laundry to 2- 3x a day. Refer to Troubleshooting Section IV-A
Normal operation: typically less than 2 years of use since last pumping	Light brown to medium brown	None	5 – 30%	Clear	No signs of plugging	None: typical operation condition	No action required; re-check in 6 months
Normal operation: 2-3 years of use since last pumping	Medium brown to dark brown	None	20 – 50%	Clear	No plugging or slight plugging observed	No immediate problem. May require pumping in the next 6 months	None; re-check in 6 months (routine) Pumping may be recommended if not on service contract (refer to Troubleshooting Section IV, Pumping)
Normal operation: typically 3 – 5 years of use since last pumping	Very dark brown with heavy brown foam. Possible foaming problems (refer to Troubleshooting Section V)	Slight	> 50%	Clear	Slight to moderate plugging. Water level surges when flow enters the plant.	Plant needs to be pumped	1. Pump sludge from tank 2. Replace filters if plugging is observed (i.e., water level remains elevated in surge bow)
Plant in operation for more than 3 months: poor treatment	Grey, minimal turbulence	Slight to moderate septic odor	< 5%	Turbid to bluish grey	Possible plugging within 3 – 4 months	Insufficient aeration	Refer to Troubleshooting Section I: Aerator
Plant in operation for more than 3 months: poor treatment	Bluish grey, similar to dishwater; white soap suds with overflow of white suds under lid. Good turbulence observed.	Slight	< 5%	Turbid, cloudy	Plugging with 2 – 3 months.	Organic overload	Refer to Troubleshooting Section VI – D
Previous plant operation has been normal. Sudden unexpected development of poor treatment and operation	Grey to black	Strong, may be septic or from some type of chemical	0 – 50%	Turbid to bluish grey	Possible plugging, greyish slime observed on filter hanger plate	Discharge of toxic materials into plant	1. Identify source of toxic material 2. Eliminate above source 3. Pump plant and re-start. Contact factory.

MULTI-FLO WASTE TREATMENT SYSTEM GENERAL OPERATIONAL TIPS

UNIT MUST RUN 24 HOURS PER DAY: If leaving residence unoccupied for long periods of time, contact your servicing dealer. Timers should not be installed unless specifically authorized by the servicing dealer.

DETERGENTS: Low sudsing detergents should be used. If powdered detergents are used, only the concentrated forms are recommended. Filler materials used in the "economy size" containers do not dissolve readily. Below are a few suggestions:

Ultra Cheer with advance color guard powder
Liquid Tide with bleach alternative
Ultra ERA liquid
Arm and Hammer Powder with Bleach
Lanosoft (available thru your dealer)

NEVER USE MORE THAN THE MANUFACTURER'S RECOMMENDED AMOUNT OF DETERGENT: If excessive sudsing or foaming occurs during laundry, reduce the amount of detergent used to 1/2 of the recommended amount.

BLEACH: Chlorine bleach should not be used. Oxygen bleaches are recommended. Oxygen bleaches can be used in any form, liquid, powder, or pellets. Most laundry detergents contain sodium perborate or bleach which releases boron as it breaks down. Boron has a bactericidal effect which in excessive quantities could damage your treatment plant so that it is wise to keep bleach levels to a minimum.

DRAIN CLEANERS: Non-caustic biodegradable drain and toilet bowl cleaners are recommended when available. **DO NOT USE TOILET BOWL CLEANERS SUCH AS 2000 FLUSHED; OR DRAINE CLEANERS SUCH AS DRANO.**

GARBAGE DISPOSAL: Care should be taken not to dispose of grease or fat in the disposal. Food scraps should be scraped into the garbage container and not flushed down the disposal.

NEVER flush paper towels, newspapers, wrapping paper, feminine articles, and rags into the system.

NEVER allow large, irregular, intermittent or constant volumes of clear water into the system as with a leaking toilet or faucet. Do not allow the water softener waste discharge line to be connected to the aerobic system.

WASHING MACHINES are responsible for large volumes of water entering the system all at once. This surge of water can hydraulically overload the unit and interfere with the smooth operation of the system. Space washings throughout the week rather than doing several loads in one day.

COOKING OILS AND GREASE are troublemakers. The type of bacteria found in aerobic systems do not live well in solidified grease. **GREASE AND COOKING FATS SHOULD NEVER BE PLACED DOWN ANY DRAINS.**

Under no circumstances should you put any of the following products down the sink, toilets or drains as they will significantly affect the efficiency of your sewage plant: medicines, cooking oil or melted fat, motor oils or other car products, garden chemicals, paints, paint thinners and other solvents.

Please read the owners manual and the conditions of the warranty. Your aerobic system is a biological treatment system designed to achieve a high degree of treatment of domestic sewage. Providing routine maintenance and following the recommendations of the owner's manual and your authorized servicing agent will help insure optimum performance as well eliminate the cost of unnecessary service calls.

Recommended Prohibitions in an On-Site System

The following is a collaborative effort of wastewater professionals to list items which can cause on-site treatment systems to operate below their potential. These items are known to have caused failures of on-site treatment systems and must be considered if the waste generated by from a particular site will contain them in excessive quantities. Since excessive is a subjective word, it is highly recommended by NOWRA to share these concerns with a Professional Engineer or Designer to identify a treatment strategy for the particular needs.

Inert Materials: Plastics, Rubber, Souring Pads, Dental Floss, Cigarette Filters, Bandages, Hair, Mop Strings, Lint, Rags, Cloth and Towels do not degrade in an on-site treatment system. Inert Materials will build up solids, and lead to system malfunction, clogging or increased pump out frequency.

Paper Products: Disposable Diapers, Paper Towels, Baby Wipes, Facial Tissues, Moist Toilet Paper are not designed to dissolve in an on-site treatment systems. Excessive Amounts of toilet tissue will not decompose. All can lead to system malfunction, back-up or increased pump out frequency.

Food Wastes: Do not put Animal Fats & Bones, Grease, Coffee Grounds, Citrus & Mellon Rinds, Corn Cobs, Egg Shells, down the sink. Garbage disposal use should limited to waste that cannot be scooped out and thrown in the trash. Spoiled Dairy Products and Yeasts from home Brewery or baking may cause excessive growth of microbes that do not degrade sewage.

Medicines: Do not flush Baby Wipes, Lotion, Scented or Quilted Toilet tissue, Female Sanitary Products, Cotton balls or swabs, Condoms or expired Medicines/Antibiotics. Septic Tank additives generally do more harm than good. Automatic Disinfection Tablets (blue, clear or otherwise) will kill the organisms needed to consume waste.

Chemical & Toxins: Kill the microbes necessary for treatment. Paint, Paint Thinner, Solvents, Volatile Substances, Drain Cleaners, Automatic Fluids, Fuels, Pesticides, Herbicides, Fertilizers, Metals, Disinfectants, Sanitizers, Bleach, Mop water, Excessive use of Household chemicals, and Backwash Water Softener regeneration.

Laundry Practices: On-site systems must process the water as it enters the systems. Laundry should be spread out over the week, not all run at one time. Excessive use of Detergents, especially those containing bleach, can affect system performance. Liquid detergents are recommended over powders. Fabric Softener sheets are recommended over liquid softeners. Bleach should be used sparingly and at half the rate indicated on the container.

Clear Water Waste: From A/C Discharge lines, Floor Drains, Gutters, Whole House Water Treatment Systems Sump Pumps can increase the flow to your treatment systems. These flows can at least disrupt, if not destroy your treatment process.

MULTI-FLO

WASTEWATER TREATMENT SYSTEMS

PUMPING INSTRUCTIONS

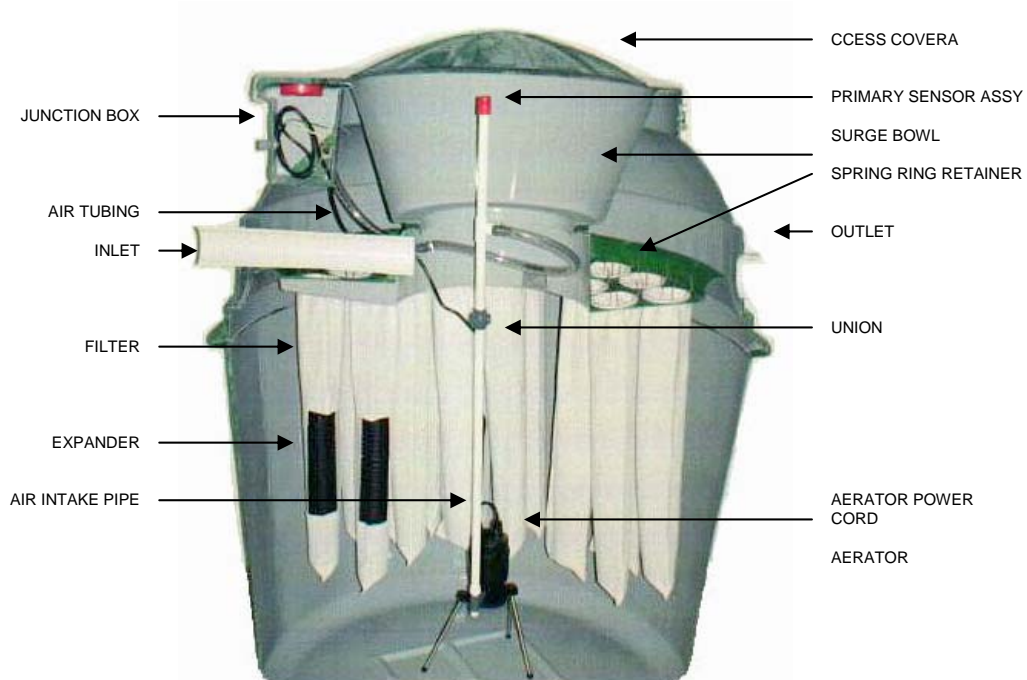

PROCEDURE FOR PUMPING THE **MULTI-FLO**:

1. Shut off the **MULTI-FLO** and allow solids to settle for 30-to-60 minutes.
2. Remove access cover and the surge bowl.
3. Lower hose carefully into the center aeration chamber. Care should be taken to avoid knocking or damaging the aerator, air intake tubing or power cord. Be especially careful with the old style FTB 0.75 as the aerator sits on a platform.
4. Pump solids from the bottom. If the filters are not removed, be sure to rinse the filters and the bottom of the hanger plate.
5. In areas with a high water table, immediately re-fill the tank with clear water to prevent shifting or floatation. In all instances, re-fill the tank to a level that covers the aerator. **To prevent the motor from overheating, do not allow the aerator to run unsubmerged.**